



January 24, 2024

NOTICE OF BID
BL004-24
Miscellaneous Milling and Paving at F. Wayne Hill Water Resources Center

The Gwinnett County Board of Commissioners is soliciting competitive sealed bids from qualified contractors for the **Miscellaneous Milling and Paving at F. Wayne Hill Water Resources Center** for the Gwinnett County Department of Water Resources.

Bid submittal date and location

Bids should be typed or submitted in ink and returned in a sealed container marked on the outside with the BL# and Company Name. Bids will be received until **2:50 P.M. local time on March 01, 2024** at the Gwinnett County Purchasing Division, 75 Langley Drive, Lawrenceville, Georgia 30046. Any bid received after this date and time will not be accepted. Bids will be publicly opened and read at 3:00 P.M. Apparent bid results will be available the following business day on our website www.gwinnettcounty.com.

Pre-Bid Conference

A pre-bid conference is scheduled for **10:00 A.M. on February 07, 2024**, at F. Wayne Hill Water Resources Center (FWHWRC) Conference Room located at 1500 One Water Way, Buford, GA 30519. All interested parties are urged to attend. The pre-bid conference is to be utilized by contractors and subcontractors to ask any questions in order to submit a bid for this project. All bidders are strongly urged to attend.

Project Description

The main objective of this Scope of Work is to mill and overlay the existing asphalt on the road between the Secondary Clarifiers and the Biological Reactors and to widen the existing pavement where trucks have driven off the pavement at the truck scale. The focus of this project is to perform pavement rehabilitation as well as provide additional pavement in two select areas. The rehabilitation will be performed at the secondary clarifiers and the additional pavement will be placed adjacent to the truck scale. Additionally, this scope also includes demolition of concrete pads at the front gate and remediation of the area with pavement and turf.

Safety Protocol

During the pre-bid conference and the bid opening, we ask that you wear a mask and practice social distancing.

Instructions on Submitting Questions

Questions regarding bids should be directed to Brittany Bryant, Purchasing Associate II, at Brittany.Bryant@GwinnettCounty.com or by calling 770-822-7759, **no later than 3:00 P.M. on February 20, 2024**. Bids are legal and binding upon the bidder when submitted. All bids should be submitted in duplicate.

Bonding and Insurance

All contractors must submit with bid, a bid bond, certified check or cashier's check in the amount of five percent (5%) of the total bid. **Failure to submit a bid bond with the proper rating will result in the bid being deemed non-responsive.** The successful contractor will be required to meet insurance requirements, submit a one hundred percent (100%) performance bond and a one hundred percent (100%) payment bond. Insurance and Bonding Company should be licensed to do business by the Georgia Secretary of State, authorized to do business in Georgia by The Georgia Insurance Department, listed in the Department of Treasury's Publication of Companies holding Certificates of Authority as Acceptable Surety on Federal Bonds and as acceptable reinsuring companies. **The bid bond, payment bond, and performance bond must have an A.M. Best rating of A-V or higher.**

Facility Access

Gwinnett County does not discriminate on the basis of disability in the admission or access to its programs or activities. Any requests for reasonable accommodations required by individuals to fully participate in any open meeting, program or activity of Gwinnett County Government should be directed to the ADA Coordinator, Gwinnett County Justice and Administration Center, 770-822-8165.

The written bid documents supersede any verbal or written prior communications between the parties.

Award will be made to the contractors submitting the lowest responsive and responsible bid. Gwinnett County reserves the right to reject any or all bids to waive technicalities and to make an award deemed in its best interest. Bids may be split or awarded in entirety. Gwinnett County reserves the option to negotiate terms, conditions and pricing with the lowest responsive, responsible bidder(s) at its discretion.

Award notification will be posted after award on the County website, www.gwinnettcountry.com and companies submitting a bid will be notified via email.

We look forward to your bid and appreciate your interest in Gwinnett County.

Brittany Bryant, CPPB
Purchasing Associate III

BID CHECKLIST
Documents that should be submitted at the time of bid opening.

ITEM #	DESCRIPTION	PAGE #
1	Product Information	9
2	Bid Schedule	10-12
3	Contractor Information	13
4	Bidder's Affidavit	14
5	Form of Non-Collusion Affidavit	15
6	References	16
7	List of Subcontractors	17
8	<u>Bid Bond (MUST BE SUBMITTED WITH BID)</u>	<u>18-19</u>
9	CONTRACTOR AFFIDAVIT AND AGREEMENT	46
10	Code of Ethics	47

1. **Background**

The main objective of this Scope of Work is to mill and overlay the existing asphalt on the road between the Secondary Clarifiers and the Biological Reactors and to widen the existing pavement where trucks have driven off the pavement at the truck scale. The focus of this project is to perform pavement rehabilitation as well as provide additional pavement in two select areas. The rehabilitation will be performed at the secondary clarifiers and the additional pavement will be placed adjacent to the truck scale. Additionally, this scope also includes demolition of concrete pads at the front gate and remediation of the area with pavement and turf. F. Wayne Hill Water Resources Center is located at 1500 One Water Way, Buford, GA 30519. These areas are shown in **Figure 1** below and are shown in more detail in the drawings included in **Attachment A**.

There is an existing road between the secondary clarifiers and the biological basins. This road is showing wear and cracking which will require milling and pavement overlay. On the west drive side at the truck scale, the existing road width is inadequate for the large vehicles and there is a worn strip of the shoulder where vehicles regularly travel off the pavement. The existing pavement needs to be widened along this section. The following photos (**Photos 1 through 4**) indicate the typical conditions of the existing paving that requires milling, and pavement overlay along the road adjacent to the secondary clarifiers. Additional photos are shown in the drawings included in **Attachment A**.

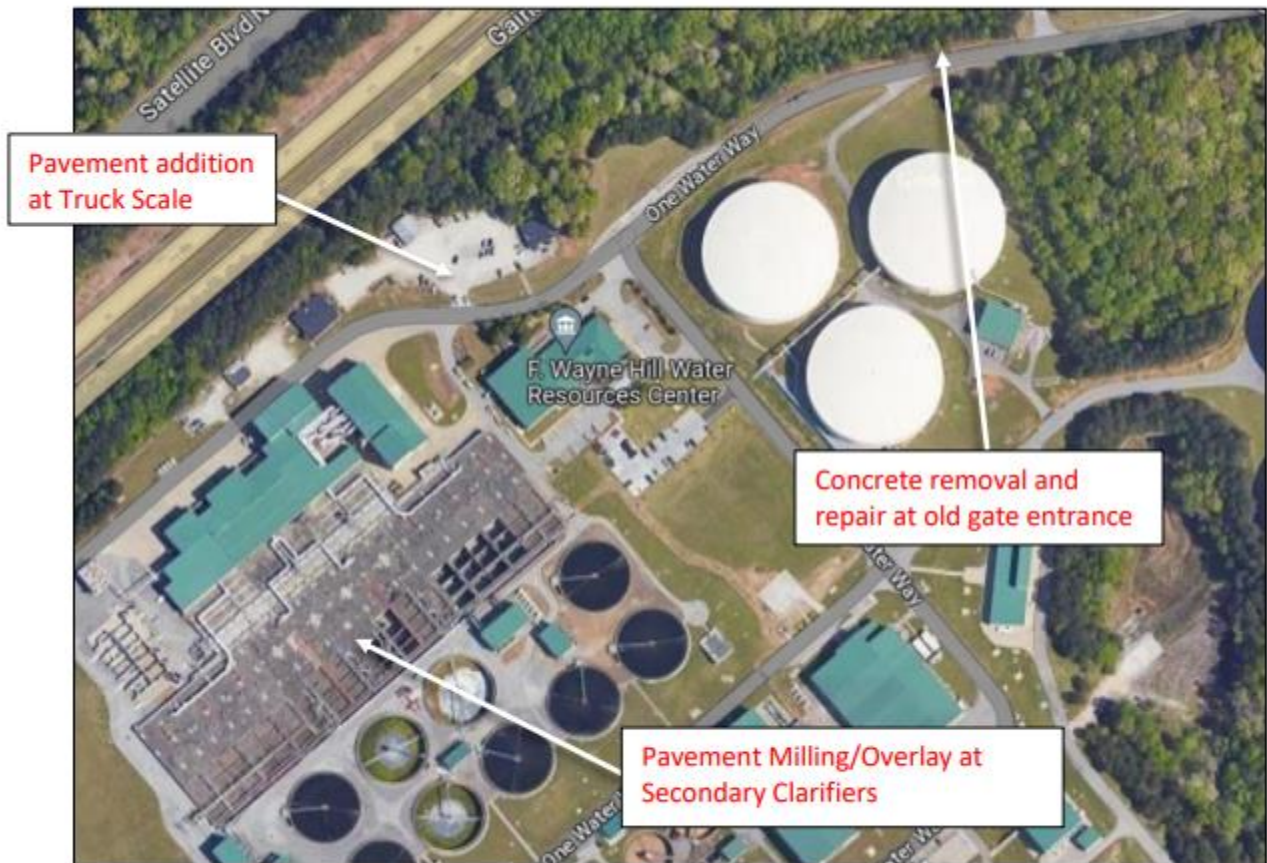

Figure 1 – Locations of pavement addition and rehabilitation areas at FWHWRC



Photo 1: View of Pavement near Secondary Clarifiers



Photo 2: View of Pavement near Secondary Clarifiers



Photo 3: View of Cracked MH Cover Collar



Photo 4: View of Depressed MH Cover Collar

The following photos (**Photos 5 and 6**) show where truck tires have left the pavement creating rutting and wear along the existing road shoulder at the exit of the truck scale. This is the location of the planned pavement widening as indicated on **Sheet 2** of the drawings included in **Attachment A**.



Photo 5: View of pavement edge near scale



Photo 6: View of pavement edge near scale

The following photo (Photo 7) shows the two concrete pads at the old plant entrance gate that need removal followed by pavement and turf restoration.



Photo 7: Two abandoned concrete pads to be removed and restored.

3.0 Project Objectives

The main objective of this Scope of Work is to mill and overlay the existing asphalt on the road between the Secondary Clarifiers and the Biological Reactors and to widen the existing pavement where trucks have driven off the pavement at the truck scale. Additionally, this scope also includes demolition of concrete pads at the front gate and remediation of the area with pavement and turf.

4.0 Scope of Work

The following scope of work (SOW) tasks are to be completed under this work order:

General:

1. A pre-proposal meeting shall be arranged if requested by Contractors to visit the facilities. Attendance shall include representatives from the Contractor, the Owner, and the Engineer. All personnel attending the site visit shall be required to bring and wear PPE (high visibility vests and hardhats) while on the site.
2. The project drawings are provided in Attachment A and the project specifications are provided in Attachment B.
3. The Contractor is to provide traffic control signage and measures as agreed with the plant staff for the period during which the work is being undertaken.
4. The Contractor shall be responsible for engaging a private utility locator to ensure no plant lines are struck during earthwork operations.
5. Disturbed areas that are to be replaced with turf shall be prepared with 4 inches of topsoil and finished with Bermuda sod.
6. If unsuitable subgrade is encountered, it shall be removed from the site and replaced with properly compacted subgrade at the Engineer's direction.
7. The Contractor shall complete the Contractor's Daily Report included in Attachment C and submit it to the Engineer the following morning.
8. The Contractor shall complete the Final Contractors Affidavit included in Attachment D upon completion of the project.

Health, Safety, and Environment (HSE):

1. Compliance with GCDWR specific safety standards on any GCDWR facility is mandatory.
2. All work is to be undertaken in conformance with applicable OSHA safety requirements, and the Contractor's project specific health and safety plan, which shall be submitted for review prior to commencing any on site work.
3. All employees of the Contractor are required to wear appropriate protective equipment while on site. Minimum protective equipment consists of steel-toed work boots, hard hat, safety vest, and eye and ear protection as deemed appropriate.
4. GCDWR staff and GCDWR construction supervision consultants shall observe and undertake ad-hoc inspections of the Contractor's safety compliance to ensure the safety of construction.

5. If any noncompliance is observed, the Contractor's supervisor/foreman will be immediately informed, and all ongoing work stopped until such time as the issue has been rectified. Note that should repeated incidents occur, the Contractor may be requested to remove an individual or team from the site either temporarily or permanently, depending on the seriousness of the incident. Permanent removal from the site will require suitably trained and committed replacement(s) who have completed as a minimum the Contractor's safety training program.
6. Prior to commencing work on site, the Contractor is required to complete and submit a Job Hazard Analysis (an example is provided in Attachment E) in which the hazards relating to the specific task are identified. As well, the Contractor is to perform field JHA's daily with crews and provide documentation of the same.
7. The contractor's staff are to confirm at the commencement of the project that they have received the required Contractor's training and are aware of the plant specific requirements by each staff member signing the example form contained in Attachment F.

The following project tasks are required under this Scope of Work:

Task 1: Removal of Asphalt

1. Secondary Clarifier:
 - Mill existing asphalt surface 1½" in depth between the indicated pavement limits.
 - Remove cracked concrete manhole top collars.
 - Remove existing concrete patch.
 - Saw cut clean line where pavement to be milled or joins to the remaining pavement.
2. Truck Scale:
 - Existing sign to be removed and replaced after completion of the pavement widening.
 - Saw cut clean line where pavement joins the remaining pavement.
 - Remove pavement to the limits shown for joining new pavement to existing pavement.
3. Front Gate
 - Remove existing concrete pads.
 - Saw cut clean line where pavement joins the remaining pavement.
 - Remove pavement to the limits shown for joining new pavement to existing pavement.

Task 2: Pavement Placement

1. Secondary Clarifier:
 - Place 1½" thick pavement overlay onto milled surfaces as shown.
 - Install new concrete manhole top collars.
 - Raise the existing manhole and water valve covers to match top of the finished pavement level. Clean site upon completion.
2. Truck Scale:
 - Add additional base material to pavement area to be widened.
 - Add additional pavement widening section as shown in attachments.
 - Reinstall removed sign at location outside of the widened pavement section.
 - Provide required testing for compaction and pavement testing.
 - Install turf grassing (sod) in areas disturbed by the installation of the new pavement.
 - Place 4-inches of topsoil with a maximum organic content of 30% before placing sod.
 - Sod shall be Tif-Tuf Blue Tag certified Bermuda Sod or Tifway 419 Blue Tag Certified Bermuda.

- 3. Front Gate
 - Add additional base material to pavement area being replaced.
 - Add additional pavement for repair adjacent to existing paving.
 - Install turf grassing (sod) to areas disturbed by the installation of the new pavement.
 - Place 4-inches of topsoil with a maximum organic content of 30% before placing sod.
 - Sod shall be Tif-Tuf Blue Tag certified Bermuda Sod or Tifway 419 Blue Tag Certified Bermuda.
 - Clean site upon completion.

The Contractor shall complete the materials list below:

DESCRIPTION	MANUFACTURER	PRODUCT INFORMATION

Attachments

- **Attachment A:** Project Drawings and Photos
- **Attachment B:** Project Specifications
 - 32 12 16 Asphalt Paving
 - 32 92 00 Turfs and Grasses
- **Attachment C:** Contractor’s Daily Report
- **Attachment D:** Final Contractor’s Affidavit
- **Attachment E:** Job Hazard Analysis Template
- **Attachment F:** Project Safety Acknowledgement

FAILURE TO RETURN THIS PAGE AS PART OF YOUR BID DOCUMENT MAY RESULT IN REJECTION.

BID SCHEDULE

ITEM #	DESCRIPTION	EST. QTY	UNIT PRICE	TOTAL PRICE
1.0	PAVEMENT MILLING AND OVERLAY AT THE SECONDARY CLARIFIERS			
1.1	Type IV Pavement, Saw Cutting	300 LF	\$	\$
1.2	Mill Existing Pavement 1-1/2" Depth	1,750 SY	\$	\$
1.3	Overlay 1-1/2" Layer-Wearing Course	1,750 SY	\$	\$
1.4	Type IV Pavement, Removal (assume 6-inch Thick)	2 CY	\$	\$
1.5	Type IV Pavement, Replacement (assume Base Course is 3/4-inch Rock, 12-inch Thick)	2 SY	\$	\$
1.6	Type IV Pavement, Replacement (assume Binder Course, 4-inch Thick)	2 SY	\$	\$
1.7	Type IV Pavement, Replacement (assume Wearing Course, 4-inch Thick)	2 SY	\$	\$
1.8	Adjust Manhole Top W/Riser Ring Manufactured by EJ Company	2 EA	\$	\$
1.9	Adjust Water Valve Box Tops W/Riser Ring Manufactured by EJ Company	2 EA	\$	\$
1.10	Remove and Replace Concrete Collar around Manhole top	2 EA	\$	\$
1.11	Remove Concrete Patch	1 EA	\$	\$
1.12	Traffic Control, Trench Plate, Testing, G&A, Locates, Other Items	1 EA	\$	\$
2.0	PAVEMENT WIDENING AT THE TRUCK SCALE			
2.1	Excavate for Subbase	1 EA	\$	\$
2.2	Type IV Pavement, Saw Cutting	175 LF	\$	\$
2.3	Type IV Pavement, Removal (assume 7.5-inch Thick) (Trench Width)	10 CY	\$	\$
2.4	Type IV Pavement, Replacement (assume Base Course is 3/4-inch Rock, 12-inch Thick)	45 SY	\$	\$
2.5	Type IV Pavement, Replacement (assume Binder Course, 5-inch Thick)	80 SY	\$	\$
2.6	Type IV Pavement, Replacement (assume Wearing Course, 2.5-inch Thick)	80 SY	\$	\$
2.7	Turf Grassing – placement of topsoil and sod	60 SY	\$	\$
2.8	Sign Removal and Relocate	1 EA	\$	\$
2.9	Traffic Control, Trench Plate, Testing, G&A, Locates, Other Items	1 EA	\$	\$
3.0	Concrete Slab Removal and Rehabilitation at Old Gate Entrance			
3.1	Remove Concrete Slabs	2 EA	\$	\$

COMPANY NAME _____

FAILURE TO RETURN THIS PAGE AS PART OF YOUR BID DOCUMENT MAY RESULT IN REJECTION.

BID SCHEDULE CONTINUED

ITEM #	DESCRIPTION	EST. QTY	UNIT PRICE	TOTAL PRICE
3.2	Type IV Pavement, Saw Cutting (LF)	30 LF	\$	\$
3.3	Type IV Pavement, Removal (assume 6-inch Thick) (Trench Width) (CY)	1 CY	\$	\$
3.4	Type IV Pavement, Replacement (assume Base Course is 3/4-inch Rock, 12-inch Thick) (SY)	3 SY	\$	\$
3.5	Type IV Pavement, Replacement (assume Binder Course, 4-inch Thick) (SY)	6 SY	\$	\$
3.6	Type IV Pavement, Replacement (assume Wearing Course, 4-inch Thick)	6 SY	\$	\$
3.7	Traffic Control, Trench Plate, Testing, G&A, Locates, Other Items	1 EA	\$	\$
3.8	Turf Grassing – placement of topsoil and sod	3 SY	\$	\$
4.0	UNFORESEEN CONDITIONS			
4.1	Remove and Replace Unsuitable Subgrade Material (if recommended by Engineer)	50 SY	\$	\$
OVERALL TOTAL (ITEMS 1.1-4.1)				\$

COMPANY NAME _____

FAILURE TO RETURN THIS PAGE AS PART OF YOUR BID DOCUMENT MAY RESULT IN REJECTION.

BID SCHEDULE CONTINUED

Pricing shall include all labor, materials, bailing, shoring, removal, a men's and women's temporary trailer (restroom and shower), overhead (Direct and indirect), profit, insurance, bonds, and other costs, to cover all finished Work.

Bidder agrees this Bid shall be good and may not be withdrawn for a period of sixty (60) calendar days after scheduled closing time for receiving bids.

There is enclosed herewith a certified or cashier's check or a Bid Bond to the order of Gwinnett County, Georgia, in the sum of Dollars _____

Check or Bid Bond shall be equal to, not less than, the amount stipulated in NOTICE TO BID and it is understood and agreed that said check or Bid Bond shall be subject to terms and conditions stipulated in Bid Document Package.

Undersigned Bidder hereby agrees to each and every stipulation in Bid Document Package pertaining to the submission of Bids and further, if awarded the Contract, duly agrees to execute and secure the required Contract and Bid Document Package within fifteen (15) days from service of Notice of Award and deliver a surety bond or bonds as required by General Conditions. The name and business address of Bidder to which all formal Notices shall be sent:

Undersigned Bidder states the names and addresses of persons interested as principals in this Bid are as follows: (Write first name in full):

Bidder shall state on line below, if a corporation, the name of State in which incorporated and the date of said incorporation:

Undersigned Bidder states (he/she/they) (is a/are) citizen(s) of the United States and all partners, associates, or principals interested herein are citizens of the United States, except: (Give full names and addresses):

COMPANY NAME _____

FAILURE TO RETURN THIS PAGE AS PART OF YOUR BID DOCUMENT MAY RESULT IN REJECTION.

CONTRACTOR INFORMATION

The undersigned acknowledges receipt of the following addenda, listed by number and date appearing on each:

Addendum No.	Date	Addendum No.	Date
_____	_____	_____	_____
_____	_____	_____	_____

Certification Of Non-Collusion in Bid Preparation _____
(Signature) (Date)

The County requires that all who enter into a contract for the physical performance of services with the County must satisfy O.C.G.A. § 13-10-91 and Rule 300-10-1-.02, in all manner, and such are conditions of the contract.

In compliance with the attached specifications and O.C.G.A. §36-91-50, the undersigned offers and agrees, if this bid is accepted by the Board of Commissioners within sixty (60) days of the date of bid opening, to furnish any or all of the items upon which prices are quoted, at the price set opposite each item, delivered to the designated point(s) within the time specified in the bid schedule. By submission of this bid, I understand that Gwinnett County uses Electronic Payments for remittance of goods and services. Vendors should select their preferred method of electronic payment upon notice of award. For more information on electronic payments, please refer to the Electronic Payment information in the instructions to bidders.

Legal Business Name _____

Address _____

Does your company currently have a location within Gwinnett County? Yes No

Representative Signature _____

Print Authorized Representative's Name _____

Telephone Number _____ Fax Number _____

E-Mail Address _____

Contact Person (if someone other than the authorized representative listed above) _____

Telephone Number _____ Fax Number _____

E-Mail Address _____

BIDDER'S AFFIDAVIT

(This Bidder's Affidavit is part of the Bid Documents)

BID NUMBER: BL004-24

BID DATE: MARCH 01, 2024

PROJECT NAME: RENOVATION OF THE OPERATIONS BUILDING BATHROOM AT F. WAYNE HILL WATER RESOURCES CENTER

STATE OF _____)

COUNTY OF _____)

(Name Printed)

being duly sworn, deposes and says that he resides at _____

that he is the

(Title)

(Name of Bidder)

who signed the above Bid Form, that he was duly authorized to sign and that the Bid is the true offer of the Bidder, that the seal attached is the seal of the Bidder and that all the declarations and statements contained in the Bid are true to the best of his knowledge and belief.

(Affiant)

Subscribed and Sworn to before me this _____ Day of _____ 20 _____

(Notary Public)

My Commission expires _____, 20 _____

(SEAL)

FORM OF NON-COLLUSION AFFIDAVIT

(This Non-Collusion Affidavit is Part of the Bid Documents)

BID NUMBER: BL004-24

BID DATE: MARCH 01, 2024

PROJECT NAME: RENOVATION OF THE OPERATIONS BUILDING BATHROOM AT F. WAYNE HILL WATER RESOURCES CENTER

STATE OF _____)
)
 SS.
 COUNTY OF _____)

_____ being first duly sworn, deposes and says that he is

_____ (sole owner, partner, president, secretary, etc.)

the party making the foregoing Proposal or Bid; that such Bid is genuine and not collusive or sham; that said Bidder has not colluded, conspired, connived, or agreed, directly or indirectly, with any Bidder or person, to put in a sham Bid, or that such other person shall refrain from bidding, and has not in any manner, directly or indirectly sought by agreement or collusion, or communication or conference, with any person, to fix the Bid Price of affiant or any other Bidder, or to fix any overhead, profit or cost element of said Bid Price, or of that of any other Bidder, or to secure any advantage against Gwinnett County, or any person interested in the proposed Contract; and that all statements in said Proposal or Bid are true; and further, that such Bidder has not, directly or indirectly submitted this Bid, or the contents thereof, or divulged information or data relative thereto to any association or to any member or agent thereof.

_____ (Affiant)

Subscribed and Sworn to before me this _____ Day of _____ 20 _____

_____ (Notary Public in and for)

_____ (County)

My Commission expires _____, 20 _____

(SEAL)

FAILURE TO RETURN THIS PAGE AS PART OF YOUR BID DOCUMENT MAY RESULT IN REJECTION.

REFERENCES

Gwinnett County requests a minimum of three (3) references where work of a similar size and scope has been completed.

Note: References should be customized for each project, rather than submitting the same set of references for every project bid. The references listed should be of similar size and scope of the project being bid on. Do not submit a project list in lieu of this form.

1. Company Name _____
Brief Description of Project _____
Completion Date _____
Contract Amount \$ _____ Start Date _____
Contact Person _____ Telephone _____
E-Mail Address _____

2. Company Name _____
Brief Description of Project _____
Completion Date _____
Contract Amount \$ _____ Start Date _____
Contact Person _____ Telephone _____
E-Mail Address _____

3. Company Name _____
Brief Description of Project _____
Completion Date _____
Contract Amount \$ _____ Start Date _____
Contact Person _____ Telephone _____
E-Mail Address _____

Company Name _____

FAILURE TO RETURN THIS PAGE AS PART OF YOUR BID DOCUMENT MAY RESULT IN REJECTION.

LIST OF SUBCONTRACTORS

I do _____, do not _____, propose to subcontract some of the work on this project. I propose to Subcontract work to the following subcontractors:

NAME AND ADDRESS	TYPE OF WORK

Company Name _____

BID BOND

KNOW ALL MEN BY THESE PRESENTS: that

(Name of Contractor)

(Address of Contractor)

a _____
(Corporation, Partnership or Individual)

hereinafter called Principal, and

(Name of Surety)

(Address of Surety)

a Corporation of the State of _____, and a surety authorized by law to do business in the State of Georgia, hereinafter called Surety, are held and firmly bound unto

Gwinnett County Board of Commissioners
(Name of Obligee)

75 Langley Drive, Lawrenceville, Georgia 30046
(Address of Obligee)

Thereinafter referred to as Obligee: in the penal sum of _____
_____ Dollars

(\$ _____) in lawful money of the United States, for the payment of which sum will and truly to be made, we bind ourselves, our heirs, executors, administrators and successors, jointly and severally, firmly by these presents.

WHEREAS, the Principal is about to submit, or has submitted, to Gwinnett County, Georgia, a proposal for furnishing materials, labor, and equipment for: _____

WHEREAS, the Principal desires to file this Bond in accordance with law in lieu of a certified Bidder's check otherwise required to accompany this Proposal.

NOW, THEREFORE, the conditions of this obligation are such that if the proposal be accepted, the Principal shall within ten days after receipt of notification of the acceptance, execute a Contract in accordance with the Proposal and upon the terms, conditions, and prices set forth in the form and manner required by Gwinnett County, Georgia, and execute a sufficient and satisfactory Performance Bond and Payment Bond payable to Gwinnett County, Georgia, each in the amount of 100% of the total Contract Price, in form and with security satisfactory to said Gwinnett County, Georgia, and otherwise, to be and remain in full force and virtue in law, and the Surety shall, upon failure of the Principal to comply with any or all of the foregoing requirements within the time specified above, immediately pay to Gwinnett County, Georgia, upon demand, the amount hereof in good and lawful money of the United States of America, not as a penalty, but as liquidated damages.

PROVIDED, FURTHER, that Principal and Surety agree and represent that this bond is executed pursuant to and in accordance with the applicable provisions of the Official Code of Georgia Annotated, as Amended, including, but not limited to, O.C.G.A. § 36-91-1 et seq., and is intended to be and shall be constructed as a bond in compliance with the requirements thereof.

Signed, sealed and dated this _____ day of _____, A.D., 20_____.

ATTEST:

(Principal Secretary)
(SEAL)

(Principal)

By: _____

(Address)

(Witness as to Principal)

(Address)

(Surety)

ATTEST: By: _____
(Attorney-in-Fact)

Resident or Nonresident Agent
(SEAL)

(Address)

(Witness as to Surety)

(Address)

NOTE: If Contractor is Partnership, all partners should execute Bond. Surety Companies executing Bonds must appear on the Treasury Department's most current list (Circular 570 as amended) and be authorized to transact business in the State where the Project is located.

Principal Secretary, Principal and Witness as to Principal signature lines must be signed by three different individuals. Additionally, Resident or Nonresident Agent, Witness as to Surety, and Attorney-in-fact must be signed by three different individuals.

**GENERAL CONDITIONS
FOR GWINNETT COUNTY CONSTRUCTION CONTRACTS**

GC-1 FAMILIARITY WITH SITE

Execution of this agreement by the Contractor is a representation that the Contractor has visited the site, has become familiar with the local conditions under which the work is to be performed, and has correlated personal observations with the requirements of this agreement.

GC-2 CONTRACT DOCUMENTS

This agreement consists of Gwinnett County's request for proposals, instructions to bidders, Contractor's proposal, construction contract, Performance Bond, Payment Bond, general conditions, special provisions, specifications, plans, drawings, addenda, and written change orders.

GC-3 DEFINITIONS

The following terms as used in this agreement are defined as follows:

Change Order - a written order to the Contractor, prepared by the Engineer and issued by the County for changes in the work within the general scope of the contract documents, adjustment of the contract price, extension of the contract time, or reservation of determination of a time extension.

County - Gwinnett County, Georgia, a political subdivision of the State of Georgia, acting by and through the Chairman of its Board of Commissioners.

Day - a calendar day of twenty-four hours lasting from midnight of one day to midnight the next day.

Notice to Proceed - written communication issued by the County to the Contractor authorizing it to proceed with the work and establishing the date of commencement and completion of the work.

Substantial Completion - the date certified by the engineer when all or a part of the work, identified in the engineer's certification, is sufficiently completed in accordance with the requirements of the contract documents so that the identified portion of the work can be utilized for the purposes for which it is intended.

Work - all of the services specified, indicated, shown or contemplated by the contract documents, and furnishing by the Contractor of all materials, equipment, labor, methods, processes, construction and manufacturing materials and equipment, tools, plans, supplies, power, water, transportation and other things necessary to complete such services in accordance with the contract documents to ensure a functional and complete facility.

GC-4 CODES

All codes, specifications, and standards referenced in the contract documents shall be the latest additions, amendments and revisions of such referenced standards in effect as of the date of the request for proposals for this contract.

GC-5 REVIEW OF CONTRACT DOCUMENTS

Before making its proposal to the County, and continuously after the execution of the agreement, the Contractor shall carefully study and compare the contract documents and shall at once report to the engineer any error, ambiguity, inconsistency or omission that may be discovered, including any requirement which may be contrary to any law, ordinance, rule, or regulation of any public authority bearing on the performance of the work. By submitting its proposal, the Contractor agrees that the contract documents, along with any supplementary written instructions issued by or through the

engineer that have become a part of the contract documents appear accurate, consistent and complete insofar as can be reasonably determined. If the Contractor has reported in writing any error, inconsistency, or omission to the County, has properly stopped the effected work until instructed to proceed, and has otherwise followed the instructions of the engineer, the Contractor shall not be liable to the County for any damage resulting from any such error, inconsistency, or omission in the contract documents. The Contractor shall not perform any portion of the work without the contract documents, approved plans, specifications, products and data, or samples for such portion of the work.

GC-6 STRICT COMPLIANCE

No observation, inspection, test or approval of the County or engineer shall relieve the Contractor from its obligation to perform the work in strict conformity with the contract documents.

GC-7 APPLICABLE LAW

All applicable State laws, County ordinances, and rules and regulations of all authorities having jurisdiction over the construction of the project shall apply to this agreement. All work performed within the right of way of the Georgia Department of Transportation shall be in accordance with DOT regulations, policies and procedures. The Contractor shall comply with all laws, ordinances, rules and regulations bearing on the conduct of the work as specified and the Contractor agrees to indemnify and hold harmless the County, its officers, agents and employees, as well as the engineer, against any claim or liability arising from or based on the violation of any law, ordinance, regulation, order or decree affecting the conduct of the work, whether occasioned by the Contractor, his agents or employees.

GC-8 PERMITS & LICENSES

All permits and licenses necessary for the work shall be secured and paid for by the Contractor. If any permit, license or certificate expires or is revoked, terminated, or suspended as a result of any action on the part of the Contractor, the Contractor shall not be entitled to additional compensation or time.

GC-9 TAXES

The Contractor shall pay all sales, retail, occupational, service, excise, old age benefit and unemployment compensation taxes, consumer, use and other similar taxes, as well as any other taxes or duties on the materials, equipment, and labor for the work provided by the Contractor which are legally enacted by any municipal, county, state or federal authority, department or agency at the time bids are received, whether or not yet effective. The Contractor shall maintain records pertaining to such taxes and levies as well as payment thereof and shall make the same available to the County at all reasonable times for inspection and copying.

GC-10 DELINQUENT CONTRACTORS

The County shall not pay any claim, debt, demand or account whatsoever to any person firm or corporation who is in arrears to the County for taxes. The County shall be entitled to a counterclaim and offset for any such debt in the amount of taxes in arrears, and no assignment or transfer of such debt after the taxes become due shall affect the right of the County to offset any taxes owed against said debt.

GC-11 LIEN WAIVERS

The Contractor shall furnish the County with evidence that all persons who have performed work or furnished materials pursuant to this agreement have been paid in full prior to submitting its demand for final payment pursuant to this agreement. In the event that such evidence is not furnished, the County may retain sufficient sums necessary to meet all lawful claims of such laborers and materialmen. The County assumes no obligation nor in any way undertakes to pay such lawful claims from any funds due or that may become due to the Contractor.

GC-12 MEASUREMENT

All items of work to be paid for per unit of measurement shall be measured and certified by the Engineer.

GC-13 ASSIGNMENT

The Contractor shall not assign any portion of this agreement or moneys due therefrom without the prior written consent of the County. The Contractor shall retain personal control and shall provide personal attention to the fulfillment of its obligations pursuant to this agreement.

GC-14 FOREIGN CONTRACTORS

In the event that the Contractor is a foreign corporation, partnership, or sole proprietorship, the Contractor hereby irrevocably appoints the Secretary of State of Georgia as its agent for service of all legal process for the purpose of this contract only.

GC-15 INDEMNIFICATION

To the fullest extent permitted by law, the Contractor shall, at his sole cost and expense, indemnify, defend, satisfy all judgments, and hold harmless the County, the engineer, and their agents and employees from and against all claims, damages, actions, judgments, costs, penalties, liabilities, losses and expenses, including, but not limited to, attorney's fees arising out of or resulting from the performance of the work, provided that any such claim, damage, action, judgment, cost, penalty, liability, loss or expense (1) is attributable to bodily injury, sickness, disease, or death, or to injury to or destruction of tangible property (other than the work itself) including the loss of use resulting therefrom, and (2) is caused in whole or in part by any act or omission of the Contractor, any subcontractor, anyone directly or indirectly employed by any of them or anyone for whose acts any of them may be liable, regardless whether such claim is caused in part by a party indemnified hereunder. Such obligation shall not be construed to negate, abridge or otherwise reduce any of the rights or obligations of indemnity which would otherwise exist as to any party or person described in this agreement. In any and all claims against the County, the engineer, or any of their agents or employees by any employee of the Contractor, any subcontractor, anyone directly or indirectly employed by any of them, or anyone for whose acts any of them may be liable, the indemnification obligation contained herein shall not be limited in any way by any limitation on the amount or type of damages, compensation, or benefits payable by or for the Contractor or any subcontractor under Worker's Compensation Acts, disability benefit acts, or other employee benefit acts.

GC-16 SUPERVISION OF WORK

The Contractor shall supervise and direct the work using the Contractor's best skill and attention. The Contractor shall be solely responsible for all construction methods and procedures and shall coordinate all portions of the work pursuant to the contract subject to the overall coordination of the engineer. All work pursuant to this agreement shall be performed in a skillful and workmanlike manner.

GC-17 RESPONSIBILITY FOR WORK

The Contractor shall not be relieved from the Contractor's obligations to perform the work in accordance with the contract documents by the activities or duties of the engineer, including inspections, tests or approvals required or performed pursuant to this agreement.

GC-18 RESPONSIBILITY FOR ACTS OF EMPLOYEES

The Contractor shall be responsible to the County for the acts and omissions of its employees, subcontractors, and agents as well as any other persons performing work pursuant to this agreement. All areas within the limits of the Project which are determined by the Engineer to be unnecessarily damaged, due either directly or indirectly to the process of construction, shall be responsibility of the Contractor to correct and repair. This is not a payment item and shall be done without additional

compensation.

GC-19 PAYMENT FOR LABOR AND MATERIALS

Unless otherwise provided in this agreement, the Contractor shall provide and pay for all labor, materials, equipment, tools, construction equipment and machinery, water, heat, utilities, transportation, and other facilities and services necessary for the execution and completion of the work.

GC-20 DISCIPLINE ON WORK SITE

The Contractor shall enforce strict discipline and good order among its employees and subcontractors at all times during the performance of the work. The Contractor shall not employ any subcontractor who is not skilled in the task assigned to it. The engineer may, by written notice, require the Contractor to remove from the work any subcontractor or employee deemed by the engineer to be incompetent.

GC-21 HOURS OF OPERATION

All work at the construction site shall be performed during regular business hours, except upon the engineer's prior written consent to other work hours.

GC-22 FAMILIARITY WITH WORK CONDITIONS

The Contractor shall take all steps necessary to ascertain the nature and location of the work and the general and local conditions, which may affect the work or the cost thereof. The Contractor's failure to fully acquaint itself with the conditions which may affect the work, including, but not limited to conditions relating to transportation, handling, storage of materials, availability of labor, water, roads, weather, topographic and subsurface conditions, other separate contracts to be entered into by the County relating to the project which may affect the work of the Contractor, applicable provisions of law, and the character and availability of equipment and facilities necessary prior to and during the performance of the work shall not relieve the Contractor of its responsibilities pursuant to this agreement and shall not constitute a basis for an equitable adjustment of the contract terms. The County assumes no responsibility for any understandings or representations concerning conditions of the work made by any of its officers, agents, or employees prior to the execution of this agreement.

GC-23 RIGHT OF ENTRY

The County reserves the right to enter the site of the work by such agent as it may elect for the purpose of inspecting the work or installing such collateral work as the County may desire.

GC-24 NOTICES

Any notice, order, instruction, claim or other written communication required pursuant to this agreement shall be deemed to have been delivered or received as follows:

- (1) Upon personal delivery to the Contractor, its authorized representative, or the engineer on behalf of the County. Personal delivery may be accomplished by in-person hand delivery or bona fide overnight express service.
- (2) Three days after depositing in the United States mail a certified letter addressed to the Contractor, the County, or the engineer. For purposes of mailed notices, the County's mailing address shall be 75 Langley Drive, Lawrenceville, Georgia 30046. The Contractor's mailing address shall be the address stated in its proposal, and the engineer's mailing address shall be its address listed in the Notice to Begin Work.

GC-25 SAFETY

The Contractor shall take all reasonable precautions for the safety of all persons and property associated with the work, and the Contractor shall erect and maintain, as required by existing conditions and the progress of the work, all reasonable safeguards for the safety and protection of persons in the vicinity of the project.

GC-26 BLASTING AND EXCAVATION

The Contractor acknowledges that it is fully aware of the contents and requirements of O.C.G.A. § 25-9-1 through 25-9-12 concerning blasting and excavation near underground gas pipes and facilities and shall fully comply therewith.

GC-27 HIGH VOLTAGE LINES

The Contractor acknowledges that it is fully aware of the contents and requirements O.C.G.A. § 46-3-30 through 46-3-39 concerning safeguards against contact with high voltage lines, and the Contractor shall fully comply with said provisions.

GC-28 SCAFFOLDING AND STAGING

The Contractor acknowledges that it is the person responsible for employing and directing others to perform labor within the meaning of O.C.G.A. § 34-1-1 and agrees to comply with said provisions.

GC-29 CLEAN-UP

The Contractor shall clean up all refuse, rubbish, scrap materials, and debris caused by its operations to the end that the site of the work shall present a neat, orderly and workmanlike appearance at all times.

GC-30 PROTECTION OF WORK

The Contractor shall be responsible for maintenance and protection of the work until final completion of this agreement and acceptance of the work as defined herein. Any portion of the work suffering injury, damage or loss shall be considered defective and shall be corrected or replaced by the Contractor without additional cost to the County.

GC-31 REJECTED WORK

The Contractor shall promptly remove from the project all work rejected by the engineer for failure to comply with the contract documents and the Contractor shall promptly replace and re-execute the work in accordance with the contract documents and without expense to the County. The Contractor shall also bear the expense of making good all work of other Contractors destroyed or damaged by such removal or replacement.

GC-32 DEFECTIVE WORK

If the Contractor defaults or neglects to carry out any portion of the work in accordance with the contract documents, and fails within three days after receipt of written notice from the County or the engineer to commence and continue correction of such default or neglect with diligence and promptness, the County or the engineer may, after three days following receipt by the Contractor of an additional written notice and without prejudice to any other remedy the County may have, make good such deficiencies and complete all or any portion of any work through such means as the County may select, including the use of a new Contractor. In such case, an appropriate change order shall be issued deducting from the payments then or thereafter due the Contractor the cost of correcting such deficiencies. In the event the payments then or thereafter due the Contractor are not sufficient to cover such amount, the Contractor shall pay the difference to the County on demand.

GC-33 NEW MATERIALS

The Contractor warrants to the County that all materials and equipment furnished under this contract will be new unless otherwise specified, and the Contractor further warrants that all work will be of good quality, free from faults and defects, and in conformance with the contract documents. The warranty set forth in this paragraph shall survive final acceptance of the work.

GC-34 CONTRACTOR'S WARRANTY

If within one year after the date of substantial completion and final acceptance of the work by the County, or within such longer period of time as may be prescribed by law or by the term of any

applicable special warranty required by the contract documents, any of the work is found to be defective or not in accordance with the contract documents, the Contractor shall correct such work promptly after receipt of written notice from the County to do so. This obligation shall survive both final payment for the work and termination of the contract.

GC-35 ASSIGNMENT OF MANUFACTURERS' WARRANTIES

Without limiting the responsibility or liability of the Contractor pursuant to this agreement, all warranties given by manufacturers on materials or equipment incorporated in the work are hereby assigned by the Contractor to the County. If requested, the Contractor shall execute formal assignments of said manufacturer's warranties to the County. All such warranties shall be directly enforceable by the County.

GC-36 WARRANTIES IMPLIED BY LAW

The warranties contained in this agreement, as well as those warranties implied by law, shall be deemed cumulative and shall not be deemed alternative or exclusive. No one or more of the warranties contained herein shall be deemed to alter or limit any other.

GC-37 STOP WORK ORDERS

In the event that the Contractor fails to correct defective work as required by the contract documents or fails to carry out the work in accordance with contract documents, the County, or the engineer, in writing, may order the Contractor to stop work until the cause for such order has been eliminated. This right of the County or engineer to stop work shall not give rise to any duty on the part of the County or the engineer to execute this right for the benefit of the Contractor or for any other person or entity.

GC-38 TERMINATION FOR CAUSE

If the Contractor is adjudged bankrupt, makes a general assignment for the benefit of creditors, suffers the appointment of a receiver on account of its insolvency, or fails to supply sufficient properly skilled workers, materials, fails to make prompt payment to subcontractors or materialmen, disregards laws, ordinances, rules, regulations, or orders of any public authority having jurisdiction, or is otherwise guilty of a material violation of this agreement and fails within seven days after receipt of written notice to commence and continue correction of such default, neglect, or violation with diligence and promptness, the County may, after ten days following receipt by the Contractor of an additional written notice and without prejudice to any other remedy the County may have, terminate the employment of the Contractor and take possession of the site as well as all materials, equipment, tools, construction equipment and machinery thereon. The County may finish the work by whatever methods the County deems expedient. In such case, the Contractor shall not be entitled to receive any further payment until the work is completed. If the unpaid balance of the contract price exceeds the cost of completing the work, such excess shall be paid to the Contractor. If such costs exceed the unpaid balance, the Contractor shall pay the difference to the County on demand. This obligation for payment shall survive the termination of the contract. Termination of this agreement pursuant to this paragraph may result in disqualification of the Contractor from bidding on future County contracts.

GC-39 TERMINATION FOR CONVENIENCE

The County may, at any time upon 30 days written notice to the Contractor, terminate the whole or any portion of the work for the convenience of the County. Said termination shall be without prejudice to any right or remedy of the County provided herein. In addition, in the event this agreement has been terminated due to the default of the Contractor, and if it is later determined that the Contractor was not in default pursuant to the provisions of this agreement at the time of termination, then such termination shall be considered a termination for convenience pursuant to this paragraph.

GC-40 TERMINATION FOR CONVENIENCE - PAYMENT

In the event that the County terminates this agreement for the convenience of the County, the County shall only be liable to the Contractor for those costs reimbursable to the Contractor plus a mark-up of ten percent on the actual fully accounted cost recovered pursuant to this paragraph. In the event that it appears that the Contractor would have sustained a loss on the entire contract had it been completed, no profit shall be included or allowed hereunder and an appropriate adjustment shall be made reducing the amount of settlement to reflect the indicated rate of loss. In the event of termination for the convenience of the County, the County shall pay the Contractor the following amounts determined by the engineer:

- A. An amount for supplies, services, or property accepted by the County for which payment has not previously been made. The price to be paid for these items shall be equivalent to the aggregate price for such supplies or services computed in accordance with the price specified in this agreement appropriately adjusted for any saving of freight or other charges; and
- B. The total of:
 - (1) The costs incurred in the performance of the work terminated, including initial costs and preparatory expenses allocable thereto, but exclusive of any costs attributable to supplies or services previously paid;
 - (2) The costs of settling and paying claims arising pursuant to the termination of the work under said contracts or orders which are properly chargeable to the terminated portion of the contract (exclusive of the amounts paid or payable on account of completed items or equipment delivered or services furnished by a subcontractor or vendor prior to the effective date of the notice of termination, which amounts shall be included in the costs payable pursuant to (A)); and
 - (3) The reasonable costs of settlement, including accounting, legal, clerical, and other expenses reasonable and necessary for the preparation of settlement claims and supporting data with respect to the terminated portion of the contract and for the termination and settlement of subcontracts thereunder, together with reasonable storage, transportation, and other costs incurred in connection with the protection or disposition of property allocable to this agreement.

GC-41 TERMINATION FOR CONVENIENCE - PAYMENT LIMITATIONS

In the event of termination for the convenience of the County, the total sum to be paid to the Contractor shall not exceed the contract price as reduced by the amount of payments otherwise made, by the contract price for work not terminated, and as otherwise permitted by the contract. Except for normal spoilage, and except to the extent that the County shall have otherwise expressly assumed the risk of loss, there shall be excluded from the amounts payable to the Contractor the fair value, as determined by the engineer, of property which is destroyed, lost, stolen or damaged so as to become undeliverable to the County or to another buyer.

GC-42 COST TO CURE

If the County terminates the whole or any part of the work pursuant to this agreement, then the County may procure upon such terms and in such manner as the engineer may deem appropriate, supplies or services similar to those so terminated, and the Contractor shall be liable to the County for any excess costs for such similar supplies or services. The Contractor shall continue the performance of this agreement to the extent not terminated hereunder.

GC-43 ATTORNEY'S FEES

Should the Contractor default pursuant to any of the provisions of this agreement, the Contractor and its surety shall pay to the County such reasonable attorney's fees as the County may expend as a result thereof and all costs, expenses, and filing fees incidental thereto.

GC-44 CONTRACTOR'S RESPONSIBILITIES UPON TERMINATION

After receipt of a notice of termination from the County, and except as otherwise directed by the engineer, the Contractor shall:

1. Stop work under the contract on the date and to the extent specified in the notice of termination;
2. Place no further orders or subcontracts for materials, services or facilities, except as may be necessary for completion of such portion of the work under the agreement as is not terminated;
3. Terminate all orders and subcontracts to the extent that they relate to the performance of work terminated by the notice of termination;
4. Assign to the County in the manner, at the times, and to the extent directed by the engineer, all of the rights, title and interest of the Contractor under the orders and subcontracts so terminated, in which case the County shall have the right, at its discretion, to settle or pay any and all claims arising out of the termination of such orders or subcontracts;
5. Settle all outstanding liabilities and all claims arising out of such termination of orders and subcontracts, with the approval or ratification of the engineer, to the extent the engineer may require, which approval or ratification shall be final for all purposes;
6. Transfer title and deliver to the entity or entities designated by the County, in the manner, at the times, and to the extent, if any, directed by the engineer, and to the extent specifically produced or specifically acquired by the Contractor for the performance of such portion of the work as has been terminated:
 - (a) The fabricated or unfabricated parts, work, and progress, partially completed supplies, and equipment, materials, parts, tools, dyes, jigs, and other fixtures, completed work, supplies, and other material produced as a part of or acquired in connection with the performance of the work terminated by the notice of termination; and
 - (b) The completed or partially completed plans, drawings, information, and other property to the work.
7. Use its best efforts to sell in the manner, at the times, to the extent, and at the prices directed or authorized by the engineer, any property described in Section 6 of this paragraph, provided, however, that the Contractor shall not be required to extend credit to any buyer and further provided that the proceeds of any such transfer or disposition shall be applied in reduction of any payments to be made by the County to the Contractor pursuant to this agreement.
8. Complete performance of such part of the work as shall not have been terminated by the notice of termination; and

9. Take such action as may be necessary, or as the engineer may direct, for the protection and preservation of the property related to the agreement which is in the possession of the Contractor and in which the County has or may acquire an interest.

GC-45 RECORDS

The Contractor shall preserve and make available to the County all of its records, books, documents and other evidence bearing on the costs and expenses of the Contractor and any subcontractor pursuant to this agreement upon three days advance notice to the Contractor.

GC-46 DEDUCTIONS

In arriving at any amount due the Contractor pursuant to the terms of this agreement, there shall be deducted all liquidated damages, advance payments made to the Contractor applicable to the termination portion of the contract, the amount of any claim which the County may have against the Contractor, the amount determined by the engineer to be necessary to protect the County against loss due to outstanding potential liens or claims, and the agreed price of any materials acquired or sold by the Contractor and not otherwise recovered by or credited to the County.

GC-47 REIMBURSEMENT OF THE COUNTY

In the event of termination, the Contractor shall refund to the County any amount paid by the County to the Contractor in excess of the costs reimbursable to the Contractor.

GC-48 TERMINATION FOR CONVENIENCE - DELAY

The Contractor shall be entitled to only those damages and that relief from termination by the County as specifically set forth in this agreement. The County or the engineer may issue a written order requiring the Contractor to suspend, delay or interrupt all or any part of the work for such period of time as the County may determine to be appropriate for the convenience of the County. If the performance of the work is interrupted for an unreasonable period of time by an act of the County or engineer in the administration of this agreement, an equitable adjustment shall be made for any increase in the Contractor's costs of performance and any increase in the time required for performance of the work necessarily caused by the unreasonable suspension, delay, or interruption. Any equitable adjustment shall be reduced to writing and shall constitute a modification to this agreement. In no event, however, shall an equitable adjustment be made to the extent that performance of this agreement would have been suspended, delayed or interrupted by any other cause, including the fault or negligence of the Contractor. No claim for an equitable adjustment pursuant to this paragraph shall be permitted before the Contractor shall have notified the engineer in writing of the act or failure to act involved, and no claim shall be allowed unless asserted in writing to the engineer within ten days after the termination of such suspension, delay or interruption.

GC-49 COMMENCEMENT AND DURATION OF WORK

The Contractor shall commence work pursuant to this agreement within ten days of mailing or delivery of written notice to proceed by the County. The Contractor shall diligently prosecute the work to completion within the time specified therefore. The capacity of the Contractor's construction and manufacturing equipment and plan, sequence and method of operation and forces employed, including management and supervisory personnel, shall be such as to ensure completion of the work within the specified time. The Contractor and County hereby agree that the contract time for completion of the work is reasonable taking into consideration the average climatic conditions prevailing in the locality of the work.

GC-50 TIME OF THE ESSENCE

All time limits stated in this agreement are of the essence of this contract.

GC-51 IMPACT DAMAGES

Except as specifically provided pursuant to a stop work order or change order, the Contractor shall not be entitled to payment or compensation of any kind from the County for direct or indirect or impact damages including, but not limited to, costs of acceleration arising because of delay, disruption, interference or hindrance from any cause whatsoever whether such delay, disruption, interference or hindrance is reasonable or unreasonable, foreseeable or unforeseeable, or avoidable, provided, however, that this provision shall not preclude the recovery of damages by the Contractor for hindrances or delays due solely to fraud or bad faith on the part of the County its agents or employees. The Contractor shall be entitled only to extensions in the time required for performance of the work as specifically provided in the contract.

GC-52 DELAY

The Contractor may be entitled to an extension of the contract time, but not an increase in the contract price, for delays arising from unforeseeable causes beyond the control and without the fault or negligence of the Contractor or its subcontractors for labor strikes, acts of God, acts of the public enemy, acts of the state, federal or local government in its sovereign capacity, by acts of another separate contractor, or by an act of neglect of the County with the engineer.

GC-53 INCLEMENT WEATHER

The Contractor shall not be entitled to an extension of the contract time due to normal inclement weather. Unless the Contractor can substantiate to the satisfaction of the engineer that there was greater than normal inclement weather considering the full term of the contract using a ten year average of accumulated mean values for climatological data compiled by the U.S. Department of Commerce for Atlanta, Georgia and that such greater than normal inclement weather actually delayed the work, the Contractor shall not be entitled to an extension of time therefor.

GC-54 NOTICE OF DELAY

The Contractor shall not receive an extension of time unless a notice of a claim is filed with the County and the engineer within ten days of the first instance of such delay, disruption, interference or hindrance and a written statement of the claim is filed with the engineer and the County within 20 days of the first such instance. In the event that the Contractor fails to comply with this provision, it waives any claim, which it may have for an extension of time pursuant to this agreement.

GC-55 NOTICE OF DELAY - CONTENTS

The notice of delay referenced in the preceding paragraph shall include specific information concerning the nature of the delay, the date of commencement of the delay, the construction activities affected by the delay, the person or organization responsible for the delay, the anticipated extent of the delay, and any recommended action to avoid or minimize the delay.

GC-56 PROGRESS OF WORK

To the extent that the Contractor is entitled to additional compensation for delay, an absolute condition precedent to such entitlement shall be strict compliance with all requirements and procedures for entitlement to an extension of time herein. If the work actually in place falls behind the currently updated and approved project network schedule, and it becomes apparent from the current schedule that work will not be completed within the contract time, the Contractor agrees that it will, as necessary, or as directed by the engineer, take action at no additional cost to the County to improve the progress of the work, including increasing manpower, increasing the number of working hours per shift or shifts per working day, increasing the amount of equipment at the site, and any other measure reasonably required to complete the work in a timely fashion.

GC-57 DILIGENCE

The Contractor's failure to substantially comply with the requirements of the preceding paragraph may be grounds for determination by the County or engineer that the Contractor is failing to prosecute the work with such diligence as will ensure its completion within the time specified. In such event, the County shall have the right to furnish such additional labor and materials as may be required to comply with the schedule after 48 hours written notice to the Contractor, and the Contractor shall be liable for such costs incurred by the County.

GC-58 SET-OFFS

Any monies due to the County pursuant to the acceleration provisions of this agreement may be deducted by the County against monies due from the County to the Contractor.

GC-59 ACCELERATION - REMEDIES

The remedies of the County concerning acceleration are in addition to and without prejudice to all of the rights and remedies of the County at law, in equity, or contained in this agreement.

GC-60 TITLE TO MATERIALS

No materials or supplies shall be purchased by the Contractor or by any Subcontractor subject to any chattel mortgage or under a conditional sales contract or other agreement by which any interest is retained by the seller. The Contractor hereby warrants that it has good and marketable title to all materials and supplies used by it in the work, and the Contractor further warrants that all materials and supplies shall be free from all liens, claims, or encumbrances at the time of incorporation in the work.

GC-61 INSPECTION OF MATERIALS

All materials and equipment used in the construction of the project shall be subject to adequate inspection and testing in accordance with accepted standards and in accordance with the requirements of the contract documents. Additional tests performed after the rejection of materials or equipment shall be at the Contractor's expense.

GC-62 ENGINEER'S PRESENCE DURING TESTING

All tests performed by the Contractor shall be witnessed by the engineer unless the requirement therefor is waived in writing. The engineer may perform additional tests on materials previously tested by the Contractor, and the Contractor shall furnish samples for this purpose as requested.

GC-63 MATERIALS INCORPORATED IN WORK

The Contractor shall furnish all materials and equipment to be incorporated in the work. All such materials or equipment shall be new and of the highest quality available. Manufactured materials and equipment shall be obtained from sources, which are currently manufacturing such materials, except as otherwise specifically approved by the engineer.

GC-64 STORAGE OF MATERIALS

Materials and equipment to be incorporated in the work shall be stored in such a manner as to preserve their quality and fitness for the work and to facilitate inspection.

GC-65 PAYROLL REPORTS

The Contractor shall be required to furnish weekly payroll reports to the engineer certifying conformance with the wage rates listed in the specifications.

GC-66 CONTRACTORS' REPRESENTATIVE

Before beginning work, the Contractor shall notify the engineer in writing of one person within its organization who shall have complete authority to supervise the work, receive orders from the engineer,

and represent the Contractor in all matters arising pursuant to this agreement. The Contractor shall not remove its representative without first designating in writing a new representative. The Contractor's representative shall normally be present at or about the site of work while the work is in progress. When neither the Contractor nor its representative is present at the work site, the superintendent, foreman, or other employee in charge of the work shall be an authorized representative of the Contractor.

GC-67 SPECIALTY SUB-CONTRACTORS

The Contractor may utilize the services of specialty subcontractors on those parts of the project which, under normal contracting practices, are performed by specialty subcontractors. Neither the Contractor nor any subcontractor shall award work to any subcontractor without the prior written consent of the County. The Contractor shall not award more than seventy-five percent of the work to subcontractors.

GC-68 INSPECTION BY ENGINEERS

All work pursuant to this agreement shall be subject to inspection by the engineer for conformity with contract drawings and specifications. The Contractor shall give the engineer reasonable advance notice of operations requiring special inspection of a portion of the work.

GC-69 WORK COVERED PRIOR TO ENGINEER'S INSPECTION

In the event that work is covered or completed without the approval of the engineer, and such approval is required by the specifications or required in advance by the engineer, the Contractor shall bear all costs involved in inspection notwithstanding conformance of such portion of the work to the contract drawings and specifications.

GC-70 ENGINEER'S AUTHORITY

The engineer shall have the authority to decide all questions concerning interpretation and fulfillment of contract requirements, including, without limitation, all questions concerning the prosecution, progress, quality and acceptability of the work. Any oral decision or instruction of the engineer shall be confirmed in writing. All communications between the County and the Contractor shall be made through the engineer. The Contractor shall submit to the engineer a complete schedule of values of various portions of the work, including quantities and unit prices, aggregating the contract price. The schedule shall subdivide the work into component parts in sufficient detail to serve as the basis for progress payments during construction. Each item in the schedule of values shall include its proper share of overhead and profit. The schedule of values, when approved by the engineer, shall be used only as a basis for the Contractor's monthly request for payment and shall not be used for additions to or deductions from the contract amount.

GC-71 PROGRESS ESTIMATES

The Contractor shall also prepare a written report for the engineer's approval, on County forms, of the total amount of value of work performed to the date of submission. No progress estimate or payment shall be considered an approval or acceptance of any work performed, and all estimates and payments shall be subject to correction in subsequent estimates. Progress payments shall be made for all completed activities and for suitably stored materials.

GC-72 PROGRESS PAYMENTS

Upon completion of each monthly estimate of work performed and materials furnished, the engineer shall recommend payment to the Contractor for the estimated value of such work, materials, and equipment, less the amount of all prior payments and all liquidated damages. The Contractor will be paid 100 percent, less retainage, of the cost of materials received and properly stored but not incorporated into the work. Payments for materials or equipment stored on the site shall be conditioned upon submission by the Contractor of bills of sale to establish the County's title to such materials or equipment. No progress estimate or payment need be made when, in the engineer's judgment, the increment in the estimated value

of work performed and materials furnished since the preceding estimate is less than \$10,000.

GC-73 TIME OF PAYMENT

When the contractor has performed in accordance with the provisions of this Agreement, Gwinnett County shall pay to the contractor, within 30 days of receipt by the County of any payment request based upon work completed or service provided pursuant to the contract, the sum so requested, less the retainage stated in this Agreement, if any. In the event that Gwinnett County fails to pay the contractor within 60 days of the County's receipt of a pay request based upon work completed or service provided pursuant to the contract, the County shall pay the contractor interest at the rate of 1/2 percent per month or pro rata fraction thereof beginning the 61st day following the County's receipt of the pay request. The contractor's acceptance of progress payments or final payment shall release all claims for interest on said payments. The provisions of this agreement are intended to supersede all provisions of the Georgia Prompt Pay Act as provided by law.

GC-74 RETAINAGE

Until the payment for Substantial Completion, the County shall withhold retainage in the amount of five percent (5%) from each progress payment. When Substantial Completion is achieved, retainage shall be paid to Contractor with the final payment in accordance with the terms of Section GC-82.

GC-75 PAYMENT OF SUBCONTRACTORS

GC-75.1 GENERAL

The Contractor shall promptly pay each subcontractor upon the receipt of payment from the County. Such payment shall be made from the amount paid to the Contractor pursuant to the subcontractor's work. The Contractor shall also maintain the records of the percentage retained from payments to the Contractor pursuant to such subcontractor's work. The Contractor shall procure agreements from each subcontractor requiring each subcontractor to pay their subcontractors, agents and employees in a similar manner.

GC-75.2 SUBCONTRACTOR RETAINAGE RELEASE

Upon request by Contractor, the County may, in its sole discretion, permit an amount equal to the retainage associated with a subcontractor's work to be released from the retainage held by the County upon completion of the subcontractor's work. To request subcontractor retainage release, Contractor shall submit a written request to the County that (a) certifies the subcontractor's work is complete and specifies the amount of retainage withheld by Contractor, (b) contains a release of all claims by the subcontractor, and (c) is executed by the Contractor, subcontractor, and, if required by the County, the engineer.

GC-76 COUNTY'S RESPONSIBILITIES TO SUBCONTRACTORS

Neither the County nor the engineer shall have any obligation to pay any subcontractor except as otherwise required by law.

GC-77 PROGRESS PAYMENTS - ACCEPTANCE OF WORK

Certification of progress payments, as well as the actual payment thereof, shall not constitute the County's acceptance of work performed pursuant to this agreement.

GC-78 PAYMENTS IN TRUST

All sums paid to the Contractor pursuant to this agreement are hereby declared to constitute trust funds in the hands of the contractor to be applied first to the payment of claims of subcontractors, laborers, and suppliers arising out of the work, to claims for utilities furnished and taxes imposed, and to the payment of premiums on surety and other bonds and on insurance for any other application.

GC-79 JOINT PAYMENTS

The County reserves the right to issue any progress payment or final payment by check jointly to the Contractor and any subcontractor or supplier.

GC-80 RIGHT TO WITHHOLD PAYMENT

The engineer may decline to approve payment and may withhold payment in whole or in part to the extent reasonable and necessary to protect the County against loss due to defective work, probable or actual third party claims, the Contractor's failure to pay subcontractors or materialmen, reasonable evidence that the work will not be completed within the contract time or contract price or damage to the County or any other contractor on the project.

GC-81 CERTIFICATE OF SUBSTANTIAL COMPLETION

Upon the Contractor's submission of a request for a certificate of substantial completion, the engineer shall inspect the work and determine whether the work is substantially complete. If the work is substantially complete, the engineer shall issue a certificate of substantial completion of the work which shall establish the date of substantial completion, shall state the responsibilities of the County and the Contractor for security, maintenance, heat, utilities, damage to the work and insurance, and shall fix the time within which the Contractor shall complete the items submitted by the Contractor as requiring correction or further work. The certificate of substantial completion of the work shall be submitted to the County and the Contractor for their written acceptance of the responsibilities assigned to them pursuant to such certificate.

GC-82 FINAL PAYMENT

GC-82.1 GENERAL

Upon Substantial Completion of the work and upon application by the Contractor and approval by the engineer, the County shall make payment reflecting adjustments and retainage for the work as provided in this agreement.

GC-82.2 AMOUNT TO BE WITHHELD

Upon receipt of an application for final payment, the engineer shall designate amounts to be withheld from the payment for incomplete work and/or defective work to be remedied. The amounts withheld shall equal 200 percent of the value of each item of incomplete work and defective work to be remedied. Such amount shall be withheld until completion and remediation of such work.

GC-83 COMMENCEMENT OF WARRANTIES

Warranties required by this agreement shall commence on the date of final completion of the project unless otherwise provided in the certificate of substantial completion.

GC-84 FINAL PAYMENT - WAIVER OF CLAIMS

The acceptance of the substantial completion payment shall constitute a waiver of all claims by the Contractor except those previously made in writing and identified by the Contractor as unsettled at the time of application for payment at substantial completion and except for the retainage sums due at final acceptance. Following the engineer's issuance of the certificate of substantial completion and the Contractor's completion of the work pursuant to this agreement, the Contractor shall forward to the engineer a written notice that the work is ready for final inspection and acceptance and shall also forward to the engineer a final application for payment. When the engineer finds the work acceptable and determines that the contract has been fully performed, the engineer shall issue a certificate for payment which shall approve final payment to the Contractor.

GC-85 DOCUMENTATION OF COMPLETION OF WORK

Neither the final payment nor the remaining retainage shall become due until the Contractor submits the following documents to the engineer:

- A. An affidavit that all payrolls, bills for materials and equipment, and other indebtedness connected with the work have been paid or otherwise satisfied;
- B. The surety's consent to final payment; and
- C. Any other data reasonably required by the County or engineer establishing payment or satisfaction of all such obligations, including releases, waivers of liens, and documents of satisfaction of debts.

In the event that a subcontractor refuses to furnish a release or waiver as required by the County or engineer, the Contractor may furnish a bond satisfactory to the County to indemnify the County against such loss. In the event that any lien or indebtedness remains unsatisfied after all payments are made, the contractor shall refund to the County all moneys that the County may become compelled to pay in discharging such lien or other indebtedness, including all costs and reasonable attorney's fees.

GC-86 GOVERNING LAW

Each and every provision of this agreement shall be construed in accordance with and governed by Georgia law. The parties acknowledge that this contract is executed in Gwinnett County, Georgia and that the contract is to be performed in Gwinnett County, Georgia. Each party hereby consents to the Gwinnett Superior Court's sole jurisdiction over any dispute which arises as a result of the execution or performance of this agreement, and each party hereby waives any and all objections to venue in the Gwinnett Superior Court.

GC-87 CHANGES AND EXTRA WORK

GC-87.1 AUTHORITY FOR CHANGES

The County may make changes in the Drawings or Specifications and in the quantities of Work to be done under the Contract

C-87.2 CHANGE ORDERS

Without invalidating the Contract, the County may at any time or from time to time, by written order, order additions, deletions, or revisions in the Work related to the original scope of the Work. Change Orders will authorize these. Upon receipt of the Change Order, Contractor shall promptly proceed with the work involved. If any price or scope of the Work or an extension or shortening of the Contract Time is involved, an equitable adjustment will be made within the Change Order. In the event the Change Order increases the contract price, the penal amount of the Payment and Performance Bonds shall be increased as provided for in Section GC-15. All changes in the Work authorized by Change Order shall be performed under the applicable Conditions of the Contract Documents.

GC-87.3 WRITTEN NOTICE

The County may, at the request of the Contractor, issue interpretations, clarifications and other instructions as to the intent of the Contract Documents, in the form of Written Notices. The County may also, at any time, make changes in the details of the Work by issuance of a Written Notice. Upon receipt of such a Written Notice containing interpretations, clarifications and other instructions, Contractor shall proceed with the Work and comply with the Written Notice unless Contractor believes that such Written Notice entitles him to a Change in Contract Price or Time or both.

Should Contractor believe that such Written Notice entitles him to change in Contract Price or Time, or both, he shall give the County notice in writing thereof within seven (7) days after receipt of the Written Notice. Thereafter within thirty (30) days, Contractor shall document the basis for the change in Contract Price or Time. The County shall render a timely, written decision on the Contractor's request for a change in Contract Price or Time. Should the County determine that the Contractor is not entitled to a change in Contract Time or Price, the Contractor shall proceed as directed upon receipt of the County's decision. Failure to proceed shall constitute a breach of Contract and shall be a cause for the termination of the Contract. Request for a Change Order arising out of a Written Notice will not be considered without the attachment thereto of a copy of the referenced Written Notice. No claim by Contractor will be allowed if asserted after Final Payment under this Contract.

GC-87.4 EXTRA WORK

Extra work consists of new and unforeseen work determined by the County not to be covered by any of the various items for which there is a bid price or by combination of such items.

GC-87.5 VARIATION IN QUANTITIES

Wherever the estimated quantities of work to be done and materials to be furnished under this Contract are shown in any of the documents including the Proposal, they are given for use in comparing bids and the right is especially reserved except as herein otherwise specifically limited, to increase or diminish them as may be deemed reasonably necessary or desirable by County to complete the Work contemplated by this Contract, and such increase or diminution shall in no way vitiate this Contract, nor shall any such increase or diminution give cause for claims or liability for damages.

GC-88 CHANGE ORDERS

GC-88.1 GENERAL

The Contract Price may only be changed by a Written Change Order. Each change will be set forth in a Change Order prepared by the County and approved by County. Change Orders will specify (a) all additional work to be done and work to be omitted, if any, in connection with the change; (b) the basis of compensation to the Contractor for additional or omitted work; and (c) any adjustment of the time of completion of the Work. If the County determines that a change requiring additional work will cause delay in completion of Work, he will grant an equitable time extension for the changed work, or a subsequent Change Order may be issued at such time as the extent of such delay can be determined.

Upon receipt of a Change Order, Contractor shall comply therewith and perform each item of work set forth therein, furnishing all labor, material, and equipment necessary therefore, in the same manner as if such work were originally included in the Contract. In the absence of a Change Order, Contractor shall not be entitled to payment or an extension of the time of completion on account of any changes made.

GC-88.2 METHODS OF PAYMENT

The value of any work covered by a Change Order or any claim for an increase or decrease in the Contract Price shall be determined by the following method which is most advantageous to County, as determined by the County:

- A. Where the work involved is covered by unit prices contained in Contract Documents, by application of unit prices to the quantities of the items involved.
- B. By mutual acceptance of a lump sum, based on a detailed breakdown of anticipated costs plus Contractor's fee for overhead, small tools, and profit.
- C. On the basis of the actual cost of the work plus a Contractor's fee for overhead, small

tools and profit. This method of payment is herein referred to as force account work. Contractor's fee for force account work performed by his own forces shall be twenty percent (20%) for direct labor and payroll burdens; five percent (5%) for all purchased material; and Contractor's fee for subcontracted work shall be as defined hereinafter.

GC-88.3 LUMP SUM CHANGE ORDER WORK

Contractor shall prepare an estimate of all extra and deleted work as described by Written Notice, using established unit prices where they are stated in the Bidding Documents. Estimates for labor, bonds, insurance, materials, and equipment required shall otherwise be based on the provisions set forth hereinafter.

GC-88.4 CHANGE ORDERS LIMITED

Except as provided herein, no order, statement or conduct of the County or the Construction Program Manager shall be treated as a "Change Order" or entitle the Contractor to any adjustment hereunder of the Contract Price or Contract Time.

GC-88.5 NO WORK STOPPAGE

Nothing in this Article shall excuse the Contractor from proceeding with the Contract as changed.

GC-88.6 CONTRACT AMENDMENT

The amount payable to the Contractor under the Contract, the Contract Time, and the date required for performance of any part of the Work may be changed only by a Change Order to the Contract.

GC-89 FORCE ACCOUNT WORK

Force account work is an Owner-defined emergency, a sudden or unforeseen failure or malfunction of an existing system, which results in the Contractor being obligated to respond to the site of the emergency as Owner-directed. Contractor may perform work on a force account basis and will be paid for properly allocated charges which may include labor, bond premium, supplies and materials, equipment and subcontract billings, incurred in the performance of such force account work as more particularly described below:

- A. Labor: All labor shall be billed at the hourly rates specified in the bid. Regular rates will apply during normal business hours, defined as Monday through Friday, 7a.m.–5p.m. Overtime rates will apply during non-normal business hours. If premium rates apply, then overtime rates shall be defined as Monday through Friday, 5p.m.–8p.m. Accordingly, premium rates, if applicable, shall be defined as Monday through Saturday, 8p.m.–7a.m., all hours on Sundays and all County recognized holidays. A foreman shall not be used where there are fewer than two (2) laborers employed, except with the written consent of the County. Subsistence and travel allowance where required by collective bargaining agreements shall be included.

The charges for labor shall include all classifications through foremen when engaged in the actual and direct performance of the Work. They shall not include charges for such overhead personnel as assistant superintendents, superintendents, office personnel, timekeepers, and maintenance mechanics.

- B. Bonds and Insurance: For bonds and insurance premiums or increases thereto necessitated by the force account work, Contractor shall receive the actual cost to which no percent shall be added. Contractor shall furnish satisfactory evidence of the rate or rates paid for such bond and insurance.

- C. Materials: For materials accepted by the County and used as an integral part of the finished Work, Contractor shall receive the actual cost of such materials delivered on the Work, including transportation charges paid by him, exclusive of machinery rentals as hereinafter set forth.

If materials are procured by Contractor by a method which is not a direct purchase from and a direct billing by the actual supplier, the cost of such materials shall be deemed to be the lowest current wholesale price at which such materials are available in the quantities concerned and delivered to the site of the Work.

For other materials used in the construction which are not an integral part of the finished Work, such as, but not limited to, sheeting, false work and form lumber, Contractor shall be reimbursed in the amount agreed upon by the County before such work is begun. The salvage value of such material will be taken into consideration in determining the amount of reimbursement.

- D. Equipment: Contractor will be paid for the use of Contractor owned or rented equipment at seventy percent (70%) of the suggested monthly rental rates listed for such equipment in the Blue Book Rental Rates for Construction Equipment (published by Equipment Guide-Book Company of Palo Alto), except as modified below, which edition shall be the latest edition in effect at the time of commencement of the force account work. Hourly rental rates shall be calculated by dividing the listed monthly rates as modified above by 176 hours. The rental rate for equipment used in excess of eight (8) hours per day, shall be at the rate of fifty percent (50%) of the hourly rates as calculated above. The rental rates for standby equipment, when authorized by the County, shall be at the rate of fifty percent (50%) of the hourly rate for equipment in use eight (8) hours per day. No payment of rentals for standby equipment will be made for more than eight (8) hours per working day and no payment will be made for weekend days or holidays. If it is deemed necessary by Contractor to use equipment not listed in the applicable edition of the Blue Book Rental Rates, Contractor shall furnish the necessary cost data and paid invoices to the County for its use in establishment of such rental rate(s). Equipment must be in good operating condition. The rental rates paid as above provided shall include the cost of fuel, oil, lubricants, supplies, small tools, necessary attachments, repairs and maintenance of all kinds, depreciation, storage and insurance. Equipment operators will be paid for as stipulated herein.

The rental time to be paid for equipment on the Work site shall be the time the equipment is required for the force account work being performed. The time shall include the time required to move the equipment to the location of the force account work and return it to the original location or to another location requiring no more time than that required to return it to its original location. Moving time will not be paid if the equipment is used at the site of the force account work on other than such force account work. Loading and transporting costs will be allowed, in lieu of moving time, when the equipment is moved by means other than its own power. No payment for loading and transporting will be made if the equipment is used at the site of the force account work on other than such force account work. Compensation will not be allowed while equipment is inoperative due to breakdown.

For the use of equipment moved in on the work and used exclusively for work paid for on a force account basis, providing the County has agreed to said move, Contractor will be paid the equipment use rates provided for in this clause, for the cost of transporting the equipment to the location of the work and its return to its original location, and for the cost of loading and unloading the equipment, all in accordance with the following provisions:

1. The cost of transporting equipment shall not exceed the applicable minimum

- established rates by the State of Georgia Public Service commission.
2. The equipment use period shall begin at the time the equipment is unloaded at the site of the force account work, shall include each day that the equipment is at the site of the force account work, excluding Saturdays and Sundays and other legal holidays unless the force account work is performed on such days, and shall terminate at the end of the day on which the County instructs Contractor to discontinue the use of such equipment. The maximum time to be paid per day will not exceed eight (8) hours unless the equipment is in operation for a longer time.
- E. Subcontract Work: Where the Change Order applies to work being performed under a subcontract, reimbursement, including the fee for small tools, overhead and profit for the subcontractor's work performed on a force account basis shall be computed in precisely the same manner as if performed by Contractor as indicated herein. One additional allowance of five percent (5%) of the subcontractor's total costs will be granted to Contractor for overhead and profit regardless of the tier of the subcontractor. If the subcontractor elects to contract out change order work to a third (or lower) level contractor or supplier of purchased equipment, he shall not be entitled to fees, overhead or profit for such third (or lower) level work or materials. The County reserves the right to direct the Contractor to contract directly with third (or lower) level subcontractors and suppliers of purchased equipment in order to avoid paying multiple fees, overhead and profit for such third (and lower level) subcontractors and suppliers of purchased equipment. If similar work is not being performed at the Work site, and if required by County, Contractor shall obtain three (3) competitive bids for the requirements of the Change Order and the Contract Documents from Subcontractors acceptable to the County. Selection of the Subcontractor shall be subject to the approval of the County.
- F. Compensation: The compensation as set forth above shall be received by Contractor as payment in full for work done on a force account basis. At the end of each day, Contractor's Representative and Inspector shall compare records of the Work performed including classification of all laborers, ordered on a force account basis.
- G. Statements: No payment will be made for work performed on a force account basis until Contractor furnishes the County itemized statements of the cost of such force account work detailed as to the following:
1. Labor - name, classification, date, daily hours, total hours, rate, and extension of each laborer and foreman.
 2. Equipment - size, type, identification number, dates, daily hours, total hours, rental rate, and extension of each unit of machinery and equipment.
 3. Materials - quantities of supplies and materials, prices, including transportation cost and extensions.
 4. Bonds and insurance premiums.
 5. Subcontract work - force account detail as above, or progress quantities and prices of unit price or lump sum subcontracts.
 6. Payments for items under paragraphs (a) to (f) inclusive shall be conditioned upon Contractor's presentation of original receipted invoices for materials used and transportation charges. If, however, the materials used in the force account work are not specially purchased for such work but are taken from Contractor's stock, then in lieu of the original invoices, the statements shall contain or be accompanied by an affidavit of Contractor which shall certify that such materials were taken from his stock, that the price and transportation of the material as claimed represent actual cost.

- H. If, in the County's opinion, Contractor or any of his subcontractors, in performing force account work, are not making efficient use of labor, material, or equipment and/or are proceeding in a manner which is expensive to the County, the County may request the Contractor to make more efficient use of labor, material and equipment. Contractor shall in good faith comply with such requests as are reasonable. If the Contractor fails to comply with such requests, the County may independently determine the reasonable cost of the work and the Contractor will be entitled only to the reasonable cost so estimated by the County.

GC-90 DISAGREEMENT WITH ORDERS FOR CHANGE

Contractor's written acceptance of a Change Order or other order for changes shall constitute his final and binding agreement to the provisions thereof and a waiver of all claims in connection therewith, whether direct or consequential in nature. Should Contractor disagree with any order for changes, he may submit a notice of potential claim to the County, at such time as the order is set forth in the form of a Change Order. Disagreement with the provisions of an order for changes shall not relieve Contractor of his obligation under Clause GC-88, Change Orders.

GC-91 CHANGED CONDITIONS

Contractor shall notify the County in writing of the following conditions, hereinafter called "changed conditions," promptly upon their discovery and before they are disturbed:

- A. Subsurface or latent physical conditions at the site of Work differing materially from those represented in this Contract; or
- B. Unknown physical conditions at the Site of the Work of an unusual nature differing materially from those ordinarily encountered and generally recognized as inherent in work of the character provided for in this Contract.

The County will promptly investigate conditions of which it is so notified or conditions discovered by it which appear to be changed conditions, and will, as soon as practicable, issue appropriate orders or instructions. If the County determines that the conditions materially differ and that they will materially increase or decrease the costs of any portion of Work, it will issue a Change Order adjusting the compensation for such portion of Work.

INSURANCE REQUIREMENTS

1. Statutory Workers' Compensation Insurance
 - (a) Employers Liability:
 - ✓ Bodily Injury by Accident - \$100,000 each accident
 - ✓ Bodily Injury by Disease - \$500,000 policy limit
 - ✓ Bodily Injury by Disease - \$100,000 each employee
2. Commercial General Liability Insurance
 - (a) \$1,000,000 limit of liability per occurrence for bodily injury and property damage
 - (b) The following additional coverage must apply:
 - ✓ 1986 (or later) ISO Commercial General Liability Form
 - ✓ Dedicated Limits per Project Site or Location (CG 25 03 or CG 25 04)
 - ✓ Additional Insured Endorsement (Form B CG 20 10 with a modification for completed operations or a separate endorsement covering Completed Operations)
 - ✓ Blanket Contractual Liability
 - ✓ Broad Form Property Damage
 - ✓ Severability of Interest
 - ✓ Underground, explosion, and collapse coverage
 - ✓ Personal Injury (deleting both contractual and employee exclusions)
 - ✓ Incidental Medical Malpractice
 - ✓ Hostile Fire Pollution Wording
3. Auto Liability Insurance
 - (a) \$500,000 limit of liability per occurrence for bodily injury and property damage
 - (b) Comprehensive form covering all owned, non-owned, leased, hired, and borrowed vehicles
 - (c) Additional Insured Endorsement
 - (d) Contractual Liability
4. Umbrella Liability Insurance - \$1,000,000 limit of liability
 - (a) The following additional coverage must apply
 - ✓ Additional Insured Endorsement
 - ✓ Concurrency of Effective Dates with Primary
 - ✓ Blanket Contractual Liability
 - ✓ Drop Down Feature
 - ✓ Care, Custody, and Control - Follow Form Primary
 - ✓ Aggregates: Apply Where Applicable in Primary
 - ✓ Umbrella Policy must be as broad as the primary policy
5. Builder's Risk Insurance or Installation Floater Insurance required on all new structures, bridges, overpasses, culverts and railroad crossings - limit at least as broad as contract amount
6. Gwinnett County Board of Commissioners should be shown as an additional insured on General Liability, Auto Liability and Umbrella Liability policies.
7. The cancellation should provide 10 days notice for nonpayment and 30 days notice of cancellation.
8. Certificate Holder should read:

Gwinnett County Board of Commissioners
75 Langley Drive
Lawrenceville, GA 30046-6935
9. Insurance Company, except Worker' Compensation carrier, must have an A.M. Best Rating of A-5 or higher. Certain Workers' Comp funds may be acceptable by the approval of the Insurance Unit. European markets including those based in London and domestic surplus lines markets that operate on a non-admitted basis are exempt from this requirement provided that the contractor's broker/agent can provide

- financial data to establish that a market is equal to or exceeds the financial strengths associated with the A.M. Best's rating of A-5 or better.
10. Insurance Company should be licensed to do business by the Georgia Department of Insurance.
 11. Certificates of Insurance, and any subsequent renewals, must reference specific bid/contract by project name and project/bid number.
 12. The Contractor shall agree to provide complete certified copies of current insurance policy (ies) or a certified letter from the insurance company (ies) if requested by the County to verify the compliance with these insurance requirements.
 13. All insurance coverage required to be provided by the Contractor will be primary over any insurance program carried by the County.
 14. Contractor shall incorporate a copy of the insurance requirements as herein provided in each and every subcontract with each and every Subcontractor in any tier, and shall require each and every Subcontractor of any tier to comply with all such requirements. Contractor agrees that if for any reason Subcontractor fails to procure and maintain insurance as required, all such required Insurance shall be procured and maintained by Contractor at Contractor's expense.
 15. No Contractor or Subcontractor shall commence any work of any kind under this Contract until all insurance requirements contained in this Contract have been complied with and until evidence of such compliance satisfactory to Gwinnett County as to form and content has been filed with Gwinnett County. **The Acord Certificate of Insurance or a preapproved substitute is the required form in all cases where reference is made to a Certificate of Insurance or an approved substitute.**
 16. The Contractor shall agree to waive all rights of subrogation against the County, the Board of Commissioners, its officers, officials, employees, and volunteers from losses arising from work performed by the contractor for the County.
 17. Special Form Contractors' Equipment and Contents Insurance covering owned, used, and leased equipment, tools, supplies, and contents required to perform the services called for in the Contract. The coverage must be on a replacement cost basis. The County will be included as a Loss Payee in this coverage for County owned equipment, tools, supplies, and contents.
 18. The Contractor shall make available to the County, through its records or records of their insurer, information regarding a specific claim related to any County project. Any loss run information available from the contractor or their insurer relating to a County project will be made available to the county upon their request.
 19. Compliance by the Contractor and all subcontractors with the foregoing requirements as to carrying insurance shall not relieve the Contractor and all Subcontractors of their liability provisions of the Contract.
 20. The Contractor and all Subcontractors are to comply with the Occupational Safety and Health Act of 1970, Public Law 91-956, and any other laws that may apply to this Contract.
 21. The Contractor shall at a minimum apply risk management practices accepted by the contractors' industry.

Surety Bonds (If Required)

All of the surety requirements will stay the same except the Surety Company must have the same rating as item 9 above.

BONDING AND CONTRACT REQUIREMENTS

General Bond Requirements

1. Bid Bonds - Amount of bond should be 5% of contract amount and submitted with your bid. Gwinnett County form Attached. Failure to use Gwinnett County Bid Bond Form may result in bid being deemed non-responsive and automatic rejection may occur.
2. Performance Bond - (Supplied by successful vendor) - Amount of bond should be 100% of contract amount. **(MUST USE COUNTY FORM)**
3. Payment, Labor and Materials Bonds - (Supplied by successful vendor) - Amount of bond should be 100% of contract amount. **(MUST USE COUNTY FORM)**
4. Bonding company must be authorized to do business by the Georgia Insurance Department.
5. An original/certified copy of the Bonding company's Certificate of Authority or Power of Attorney must be attached to bond. The Certificate of Authority may be obtained from the Georgia Insurance Department.
6. Bonding company must have a minimum AM Best rating of A-V or higher as stated in Insurance Requirements. **Failure to submit a bid bond with the proper rating will result in the bid being deemed non-responsive.**
7. Bonding Company must be listed in the Department of the Treasury's publication of companies holding Certificates of Authority as acceptable surety on Federal Bonds and as acceptable reinsuring companies. (Dept. Circular 570; 1992 Revision).
8. After bid opening, vendor has up to forty-eight (48) hours to notify the Gwinnett County Purchasing Office of an obvious error made in calculation of Bid. Withdrawal of Bid Bond for this reason must be done in writing within the forty-eight (48) hour period. Bid Bond may not be withdrawn otherwise.

Contract Requirements

1. Successful vendor is required to do the following within ten (10) days of notification.
 - A. Return to Purchasing Office contract documents executed by the principal of the company and attested by the secretary or assistant secretary.
 - B. Provide Insurance certificates as specified in the bid documents.
 - C. Provide bonding as required by the bid documents.
2. Failure to execute the Contract, Contract Performance Bond and Payment Bond, or furnish satisfactory proof of carriage of the insurance required within ten days after the date of Notice of Award of the Contract may be just cause for the annulment of the award and for the forfeiture of the bid guaranty to Gwinnett County, not as a penalty, but as liquidation of damages sustained. At the discretion of the County, the award may then be made to the next lowest, responsible bidder, or the work may be re-advertised or constructed by County forces. The Contract and Contract Bonds shall be executed in duplicate.

*****Gwinnett County requires that all Contracts between parties be entered into via the following documents. If any exceptions are taken to any part of this document, each must be stated in detail and submitted as part of your proposal/bid document. If no exceptions are noted it is assumed that the party fully agrees to the contract in its entirety. Exceptions to the sample contract provided in this request for proposal will be considered in terms of responsiveness when making award.*****

**SAMPLE
CONTRACT**

This **CONTRACT** made and entered into this _____ day of _____, 20____ by and between Gwinnett County, Georgia (Party of the First Part, hereinafter called the County), and _____, (Party of the Second Part, hereinafter called the Contractor).

WITNESSETH: That the said Contractor has agreed, and by these presets does agree with the said County, for the consideration herein mentioned and under the provision of the Performance Bond and Payment Bond required by the Specifications to furnish all equipment, tools, materials, skill and labor of every description necessary to carry out and complete in a good, firm and substantial and workmanlike manner, the work specified, in strict conformity with the drawings and specifications, together with the foregoing proposal made by the Contractor, the Advertisement, the Instructions to Bidders, General Conditions, and this Contract, shall all form essential parts to this Contract. The work covered by this Contract includes all work shown on plans and specifications and listed in the conditions and specifications to wit:

BL004-24, Miscellaneous Milling and Paving at F. Wayne Hill Water Resources Center

The Contractor awarded work under this contract shall commence work within _____ days after the issuance of the Notice to Proceed and shall fully complete all work hereunder within _____ (_____) consecutive calendar days from and after said date.

The County shall pay and the Contractor shall receive the prices stipulated in the proposal hereto attached as full compensation for everything furnished and done by the Contractor under this contract, which shall in no event exceed (\$ _____) based on the proposal which sum shall be paid in the manner and terms specified in the Contract Documents, but before issuance of certificate of payment, if the Contractor shall not have submitted evidence satisfactory to the County that all payrolls, materials bills, and other indebtedness connected with the work have been paid, the County may withhold, in addition to the retained percentages, such amount or amounts as may be necessary to pay just claims for labor and services rendered and materials in and about the work, and such amount or amounts withheld or retained may be applied by the County to the payment of such just claims.

When the Contractor has performed in accordance with the provisions of this Contract, Gwinnett County shall pay to the Contractor, within thirty (30) days of receipt of any payment request based upon work completed or service provided pursuant to the Contract, the sum so requested, less the retainage stated in this Contract, if any. In the event that Gwinnett County fails to pay the Contractor within sixty (60) days of receipt of a pay request based upon work completed or service provided pursuant to the Contract, the County shall pay the Contractor interest at the rate of 1/2% per month or pro rata fraction thereof, beginning the sixty-first (61st) day following receipt of the pay request. The Contractor's acceptance of progress payments or final payment shall release all claims for interest on said payments.

It is further mutually agreed between the Parties hereto that if, at any time after the execution of the Contract and the Performance Bond for its faithful performance and the Payment Bond, the first party shall deem the surety or sureties upon such bond to be inadequate to cover the performance of the work, the second party shall, at its expense, within five (5) days after the receipt of notice from the first party to do so, furnish an additional bond or bonds in such form and amount, and with such surety or sureties as shall be satisfactory to the first party. In such event, no further payment to the second party

shall be deemed to be due under this Contract until such new or additional security for the faithful performance of the work shall be furnished in a manner and form satisfactory to the first party.

The parties agree that each of the provisions included in this Contract is separate, distinct and severable from the other and remaining provisions of this Contract, and that the invalidity of any Contract provision shall not affect the validity of any other provision or provisions of this Contract.

(Signatures Next Page)

IN WITNESS WHEREOF, the parties hereto, acting through their duly authorized agents, have caused this **CONTRACT** to be signed, sealed and delivered.

GWINNETT COUNTY, GEORGIA

By: _____
Nicole L. Hendrickson, Chairwoman
Gwinnett County Board of Commissioners

ATTEST:

Signature

Diane Kemp, County Clerk
Board of Commissioners

APPROVED AS TO FORM:

Signature
Gwinnett County Staff Attorney

CONTRACTOR: _____

BY: _____
Signature

Print Name

Title

ATTEST:

Signature

Print Name
Corporate Secretary
(Seal)



BL004-21, Miscellaneous Milling and Paving at F. Wayne Hill Water Resources Center

**CONTRACTOR AFFIDAVIT AND AGREEMENT
(THIS FORM SHOULD BE FULLY COMPLETED AND RETURNED WITH YOUR SUBMITTAL)**

By executing this affidavit, the undersigned contractor verifies its compliance with The Illegal Immigration Reform Enhancements for 2013, stating affirmatively that the individual, firm, or corporation which is contracting with the Gwinnett County Board of Commissioners has registered with and is participating in a federal work authorization program* [any of the electronic verification of work authorization programs operated by the United States Department of Homeland Security or any equivalent federal work authorization program operated by the United States Department of Homeland Security to verify information of newly hired employees, pursuant to the Immigration Reform and Control Act, in accordance with the applicability provisions and deadlines established therein.

The undersigned further agrees that, should it employ or contract with any subcontractor(s) in connection with the physical performance of services or the performance of labor pursuant to this contract with the Gwinnett County Board of Commissioners, contractor will secure from such subcontractor(s) similar verification of compliance with the Illegal Immigration Reform and Enforcement Act on the Subcontractor Affidavit provided in Rule 300-10-01-.08 or a substantially similar form. Contractor further agrees to maintain records of such compliance and provide a copy of each such verification to the Gwinnett County Board of Commissioners at the time the subcontractor(s) is retained to perform such service.

E-Verify * User Identification Number

Date Registered

Legal Company Name

Street Address

City/State/Zip Code

BY: _____
Authorized Officer or Agent
(Contractor Signature)

Date

Title of Authorized Officer or Agent of Contractor

Printed Name of Authorized Officer or Agent

SUBSCRIBED AND SWORN BEFORE ME ON THIS THE
____ DAY OF _____, 201__

Notary Public
My Commission Expires:_____

For Gwinnett County Use Only:
Document ID # _____
Issue Date: _____
Initials: _____

* As of the effective date of O.C.G.A. 13-10-91, the applicable federal work authorization program is "E-Verify" operated by the U.S. Citizenship and Immigration Services Bureau of the U.S. Department of Homeland Security, in conjunction with the Social Security Administration (SSA).



BL004-24, Miscellaneous Milling and Paving at F. Wayne Hill Water Resources Center
THIS FORM SHOULD BE FULLY COMPLETED AND RETURNED WITH YOUR SUBMITTAL AND WILL BE REQUIRED PRIOR TO EVALUATION

In accordance with Section 54-33 of the Gwinnett County Code of Ordinances the undersigned bidder/proposer makes the following full and complete disclosure under oath, to the best of his/her knowledge, of the name(s) of all elected officials whom it employs or who have a direct or indirect pecuniary interest in or with the bidder/proposer, its affiliates or its subcontractors:

1. _____
(Company Submitting Bid/Proposal)

2. (Please check **one** box below)

No information to disclose (*complete only section 4 below*)

Disclosed information below (*complete section 3 & section 4 below*)

3. (if additional space is required, please attach list)

_____	_____
Gwinnett County Elected Official Name	Gwinnett County Elected Official Name
_____	_____
Gwinnett County Elected Official Name	Gwinnett County Elected Official Name

4.	Sworn to and subscribed before me this
BY: _____	_____ day of _____, 20____
Authorized Officer or Agent Signature	
_____	_____
Printed Name of Authorized Officer or Agent	Notary Public

Title of Authorized Officer or Agent of Contractor	(seal)

Note: See Gwinnett County Code of Ethics Ordinance E02011, Sec. 54-33. The ordinance will be available to view in its' entirety at www.gwinnettcountry.com

BOND # _____

PAYMENT BOND

KNOW ALL MEN BY THESE PRESENTS: that

(Name of Contractor)

(Address of Contractor)

a _____
(Corporation, Partnership or Individual)

hereinafter called Principal, and

(Name of Surety)

(Address of Surety)

a Corporation of the State of _____, and a surety authorized by law to do business in the State of Georgia, hereinafter called Surety, are held and firmly bound unto

Gwinnett County Board of Commissioners
(Name of Obligee)

75 Langley Drive, Lawrenceville, Georgia 30046
(Address of Obligee)

hereinafter called Obligee,

for the use and protection of all subcontractors and all persons supplying labor, services, skill, tools, machinery, materials and/or equipment in the prosecution of the work provided for in the contract hereinafter referred to in the full and just sum of _____

_____ Dollars

(\$ _____) in lawful money of the United States, for the payment of which sum, will and truly to be made, the Principal and Surety bind themselves, their, and each of their heirs, executors, administrators, successors and assigns, jointly and severally, firmly by these presents.

The condition of this obligation is such, as whereas the Principal entered into a certain contract, hereto attached, with the Obligee.

NOW, THEREFORE THE CONDITION OF THIS OBLIGATION IS SUCH, that if the Principal shall well, truly, and faithfully perform said Contract according to its terms, covenants, and conditions, and shall promptly pay all persons furnishing labor, materials services, skill, tools, machinery and/or equipment for use in the performance of said Contract, then this obligation shall be void; otherwise it shall remain in full force and effect.

ALL persons who have furnished labor, materials, services, skill, tools, machinery and/or equipment for use in the performance of said Contract shall have a direct right of action on this Bond, provided payment has not been made in full within ninety (90) days after the last day on which labor was performed, materials, services, skill, tools, machinery, and equipment furnished or the subcontract completed.

PROVIDED FURTHER, that said Surety to this Bond, for value received, hereby stipulates and agrees that no change, extension of time, alterations, or additions to the terms of the Contract or to the Work to be performed thereunder shall in any way affect its obligation on this bond, and it does hereby waive notice of any such change, extension of time, alterations, or additions to the terms of the Contract or to the work to be performed thereunder.

PROVIDED, HOWEVER, that no suit or action shall be commenced hereunder by any person furnishing labor, materials, services, skill, tools, machinery, and/or equipment having a direct contractual relationship with a subcontractor, but no contractual relationship express or implied with the Principal:

Unless such person shall have given notice to the Principal within ninety (90) days after such person did, or performed the last of the work or labor, or furnished the last of the materials, services, skill, tools, machinery and/or equipment for which claim is made, stating with substantial accuracy the amount claimed and the name of the party to whom the materials, services, skill, tools, machinery and/or equipment were furnished, or for whom the work or labor was done or performed. Such a notice shall be served by mailing the same by registered mail, postage prepaid, in an envelope addressed to the Principal, at any place where an office is regularly maintained for the transaction of business, or served in any manner in which legal process may be served in the State in which the aforesaid project is located, save that such service need not be made by a public officer, and a copy of such notice shall be delivered to the Obligee, to the person and at the address provided for in the Contract, within five (5) days of the mailing of the notice to the Principal.

PROVIDED, FURTHER, that any suit under this bond must be instituted before the expiration of one (1) year after the acceptance of the public works covered by the Contract by the proper authorities.

PROVIDED, FURTHER, that Principal and Surety agree and represent that this bond is executed pursuant to and in accordance with the applicable provisions of the Official Code of Georgia Annotated, as Amended, including, but not limited to, O.C.G.A. § 36-91-1 et seq., and is intended to be and shall be construed as a bond in compliance with the requirements thereof.

[Signatures Next Page]

ATTEST:

(Principal Secretary)

(SEAL)

(Witness as to Principal)

(Address)

ATTEST:

Resident or Nonresident Agent

(SEAL)

(Witness as to Surety)

(Address)

(Principal)

By:

(Address)

(Surety)

By:

(Attorney-in-Fact)

(Address)

BONDING AGENT CONTACT INFO

Print Name _____

Company Name _____

E-Mail _____

Phone _____

NOTE: If Contractor is Partnership, all partners should execute Bond. Surety Companies executing Bonds must appear on the Treasury Department's most current list (Circular 570 as amended) and be authorized to transact business in the State where the Project is located.

Principal Secretary, Principal and Witness as to Principal signature lines must be signed by three different individuals. Additionally, Resident or Nonresident Agent, Witness as to Surety, and Attorney-in-fact must be signed by three different individuals.

BOND # _____

PERFORMANCE BOND

KNOW ALL MEN BY THESE PRESENTS: that

(Name of Contractor)

(Address of Contractor)

a _____
(Corporation, Partnership or Individual)

hereinafter called Principal, and

(Name of Surety)

(Address of Surety)

a Corporation of the State of _____, and a surety authorized by law to do business in the State of Georgia, hereinafter called Surety, are held and firmly bound unto

Gwinnett County Board of Commissioners

(Name of Obligee)

75 Langley Drive, Lawrenceville, Georgia 30046

(Address of Obligee)

hereinafter referred to as Obligee, are held and firmly bound unto said Obligee and all persons doing work or furnishing skill, tools, machinery, supplies, or material under or for the purpose of the Contract hereinafter referred to, in the penal sum of _____

Dollars (\$ _____) in

lawful money of the United States, for the payment of which sum will and truly to be made, we bind ourselves, our heirs, executors, administrators and successors, jointly and severally, firmly by these presents.

The condition of this obligation is such, as whereas the Principal entered into a certain contract, hereto attached, with the Obligee.

NOW, THEREFORE THE CONDITION OF THIS OBLIGATION IS SUCH, that if the Principal shall well, truly, fully and faithfully perform said contract according to its terms, covenants, conditions, and agreements of said contract during the original term of said contract and any extensions thereof that may be granted by the Obligee, with or without notice to the Surety, and during the life of any guaranty required under the contract, and shall also well and truly perform and fulfill all the undertakings, covenants, terms, conditions and agreement of any and all duly authorized modifications of said contract that may hereafter be made, then this obligation shall be void, otherwise to remain in full force and effect.

PROVIDED FURTHER, that said Surety to this Bond, for value received, hereby stipulates and agrees that no change, extension of time, alterations, or additions to the terms of the Contract or to the Work to be performed thereunder shall in any way affect its obligation on this bond, and it does hereby waive notice of any such change, extension of time, alterations, or additions to the terms of the Contract or to the work to be performed thereunder.

PROVIDED, FURTHER, that Principal and Surety agree and represent that this bond is executed pursuant to and in accordance with the applicable provisions of the Official Code of Georgia Annotated, as Amended, including, but not limited to, O.C.G.A. § 36-91-1 et seq., and is intended to be and shall be construed as a bond in compliance with the requirements thereof.

(Signatures Next Page)

ATTEST:

(Principal Secretary)

(SEAL)

(Witness as to Principal)

(Address)

ATTEST:

Resident or Nonresident Agent

(SEAL)

(Witness as to Surety)

(Address)

(Principal)

By: _____

(Address)

(Surety)

By: _____

(Attorney-in-Fact)

(Address)

BONDING AGENT CONTACT INFO

Print Name _____

Company Name _____

E-Mail _____

Phone _____

NOTE: If Contractor is Partnership, all partners should execute Bond. Surety Companies executing Bonds must appear on the Treasury Department's most current list (Circular 570 as amended) and be authorized to transact business in the State where the Project is located.

Principal Secretary, Principal and Witness as to Principal signature lines must be signed by three different individuals. Additionally, Resident or Nonresident Agent, Witness as to Surety, and Attorney-in-fact must be signed by three different individuals.

FAILURE TO RETURN THIS PAGE MAY RESULT IN REMOVAL OF YOUR COMPANY FROM COMMODITY LISTING.

BL004-24

Buyer Initials: BB

IF YOU DESIRE TO SUBMIT A "NO BID" IN RESPONSE TO THIS PACKAGE, PLEASE INDICATE BY CHECKING ONE OR MORE OF THE REASONS LISTED BELOW AND EXPLAIN.

- Do not offer this product or service; remove us from your bidder's list for this item only.
- Specifications too "tight"; geared toward one brand or manufacturer only.
- Specifications are unclear.
- Unable to meet specifications
- Unable to meet bond requirements
- Unable to meet insurance requirements
- Our schedule would not permit us to perform.
- Insufficient time to respond.
- Other

COMPANY NAME _____

AUTHORIZED REPRESENTATIVE _____
SIGNATURE

*****ATTENTION*****

FAILURE TO RETURN THE FOLLOWING DOCUMENTS MAY RESULT IN BID BEING DEEMED NON-RESPONSIVE AND AUTOMATIC REJECTION:

1. FAILURE TO USE COUNTY BID SCHEDULE.
2. FAILURE TO RETURN APPLICABLE COMPLIANCE SHEETS/SPECIFICATION SHEETS.
3. FAILURE TO RETURN APPLICABLE ADDENDA.
4. FAILURE TO PROVIDE INFORMATION ON ALTERNATES OR EQUIVALENTS.
5. THE COUNTY SHALL BE THE SOLE DETERMINANT OF TECHNICALITY VS. NON-RESPONSIVE BID.
6. FAILURE TO PROVIDE BID BOND, WHEN REQUIRED, WILL RESULT IN BID BEING DEEMED NON-RESPONSIVE AND AUTOMATIC REJECTION. BID BONDS ARE NOT REQUIRED ON ALL BIDS. BOND REQUIREMENTS ARE CLEARLY STATED ON THE INVITATION TO BID. IF YOU NEED CLARIFICATION, CONTACT THE PURCHASING ASSOCIATE. **IF BONDS ARE REQUIRED, FORMS WILL BE PROVIDED IN THIS BID DOCUMENT.**
7. FAILURE TO PROVIDE CONTRACTOR AFFIDAVIT AND AGREEMENT, WHEN REQUIRED, MAY RESULT IN BID BEING DEEMED NON-RESPONSIVE AND AUTOMATIC REJECTION. CONTRACTOR AFFIDAVIT AND AGREEMENT IS NOT REQUIRED ON ALL BIDS. IF YOU NEED CLARIFICATION, CONTACT THE PURCHASING ASSOCIATE.

**GWINNETT COUNTY DEPARTMENT OF FINANCIAL SERVICES – PURCHASING DIVISION
GENERAL INSTRUCTIONS FOR BIDDERS, TERMS AND CONDITIONS**

I. PREPARATION OF BIDS

- A. Each bidder shall examine the drawings, specifications, schedule and all instructions. Failure to do so will be at the bidder's risk, as the bidder will be held accountable for their bid response.
- B. Each bidder shall furnish all information required by the bid form or document. Each bidder shall sign the bid and print or type his or her name on the schedule. The person signing the bid must initial erasures or other changes. An authorized agent of the company must sign bids.
- C. With the exception of solicitations for the sale of real property, individuals, firms and businesses seeking an award of a Gwinnett County contract may not initiate or continue any verbal or written communications regarding a solicitation with any County officer, elected official, employee or other County representative other than the Purchasing Associate named in the solicitation between the date of the issuance of the solicitation and the date of the final contract award by the Board of Commissioners. The Purchasing Director will review violations. If determined that such communication has compromised the competitive process, the offer submitted by the individual, firm or business may be disqualified from consideration for award. Solicitations for the sale of real property may allow for verbal or written communications with the appropriate Gwinnett County representative.
- D. Sample contracts (if pertinent) are attached. These do NOT have to be filled out with the bid/proposal submittal, but are contained for informational purposes only. If awarded, the successful bidder(s) will be required to complete them prior to contract execution.
- E. Effective, July 1, 2013 and in accordance with the Georgia Illegal Immigration Reform Enhancements for 2013, an original signed, notarized and fully completed Contractor Affidavit and Agreement should be included with your bid/proposal submittal, if the solicitation is for the physical performance of services for all labor or service contract(s) that exceed \$2,499.99 (except for services performed by an individual who is licensed pursuant to Title 26, Title 43, or the State Bar of Georgia). Failure to provide the Contractor Affidavit and Agreement with your bid/proposal submittal may result in bid/proposal being deemed non-responsive and automatic rejection.

II. DELIVERY

- A. Each bidder should state time of proposed delivery of goods or services.
- B. Words such as "immediate," "as soon as possible," etc. shall not be used. The known earliest date or the minimum number of calendar days required after receipt of order (delivery A.R.O.) shall be stated (if calendar days are used, include Saturday, Sunday and holidays in the number).

III. EXPLANATION TO BIDDERS

Any explanation desired by a bidder regarding the meaning or interpretation of the invitation for bids, drawings, specifications, etc. must be requested by the question cutoff deadline stated in the solicitation in order for a reply to reach all bidders before the close of bid. Any information given to a prospective bidder concerning an invitation for bid will be furnished to all prospective bidders as an addendum to the invitation if such information is necessary or if the lack of such information would be prejudicial to uninformed bidders. The written bid documents supersede any verbal or written communications between parties. Receipt of addendum should be acknowledged in the bid. **It is the bidder's responsibility to ensure that they have all applicable**

addenda prior to bid submittal. This may be accomplished via contact with the assigned Procurement Agent prior to bid submittal.

IV. SUBMISSION OF BIDS

- A. Bids shall be enclosed in sealed envelopes, addressed to the Gwinnett County Purchasing Office with the name of the bidder, the date and hour of opening and the invitation to bid number on the face of the envelope. Telegraphic/faxed bids will not be considered. Any addenda should be enclosed in the sealed envelopes as well.
- B. ADD/DEDUCT: Add or deduct amounts indicated on the outside of the envelope are allowed and will be applied to the lump sum amount. Amount shall be clearly stated and should be initialed by an authorized company representative.
- C. Samples of items, when required, must be submitted within the time specified and, unless otherwise specified by the County, at no expense to the County. Unless otherwise specified, samples will be returned at the bidder's request and expense if items are not destroyed by testing.
- D. Items offered must meet required specifications and must be of a quality, which will adequately serve the use and purpose for which intended.
- E. Full identification of each item bid upon, including brand name, model, catalog number, etc. must be furnished to identify exactly what the bidder is offering. Manufacturer's literature may be furnished.
- F. The bidder must certify that items to be furnished are new and that the quality has not deteriorated so as to impair its usefulness.
- G. Unsigned bids will not be considered except in cases where bid is enclosed with other documents, which have been signed. The County will determine this.
- H. Gwinnett County is exempt from federal excise tax and Georgia sales tax with regard to goods and services purchased directly by Gwinnett County. Suppliers and contractors are responsible for federal excise tax and sales tax, including taxes for materials incorporated in county construction projects. Suppliers and contractors should contact the State of Georgia Sales Tax Division for additional information.
- I. Information submitted by a bidder in the bidding process shall be subject to disclosure after the public opening in accordance with the Georgia Open Records Act.

V. WITHDRAWAL OF BID DUE TO ERRORS

The bidder shall give notice in writing of his claim of right to withdraw his bid without penalty due to an error within two (2) business days after the conclusion of the bid opening procedure. Bids may be withdrawn from consideration if the price was substantially lower than the other bids due solely to a mistake therein, provided the bid was submitted in good faith, and the mistake was a clerical mistake as opposed to a judgment mistake, and was actually due to an unintentional arithmetic error or an unintentional omission of a quantity of work, labor or material made directly in the compilation of the bid, which unintentional arithmetic error or unintentional omission can be clearly shown by objective evidence drawn from inspection of original work papers, documents and material used in the preparation of the bid sought to be withdrawn. The bidder's original work papers shall be the sole acceptable evidence of error and mistake if he elects to withdraw his bid. If a bid is withdrawn under the authority of this provision, the lowest remaining responsive bid shall be deemed to be low bid.

No bidder who is permitted to withdraw a bid shall, for compensation, supply any material or labor or perform any subcontract or other work agreement for the person or firm to whom the contract is awarded or otherwise benefit, directly or indirectly, from the performance of the project for which the withdrawn bid was submitted.

Supplier has up to forty-eight (48) hours to notify the Gwinnett County Purchasing Office of an obvious clerical error made in calculation of bid in order to withdraw a bid after bid opening. Withdrawal of bid for this reason must be done in writing within the forty-eight (48) hour period. Suppliers who fail to request withdrawal of bid by the required forty-eight (48) hours shall automatically forfeit bid bond. Bid may not be withdrawn otherwise.

Bid withdrawal is not automatically granted and will be allowed solely at Gwinnett County's discretion.

VI. TESTING AND INSPECTION

Since tests may require several days for completion, the County reserves the right to use a portion of any supplies before the results of the tests are determined. Cost of inspections and tests of any item, which fails to meet the specifications, shall be borne by the bidder.

VII. F.O.B. POINT

Unless otherwise stated in the invitation to bid and any resulting contract, or unless qualified by the bidder, items shall be shipped F.O.B. Destination. The seller shall retain title for the risk of transportation, including the filing for loss or damages. The invoice covering the items is not payable until items are delivered and the contract of carriage has been completed. Unless the F.O.B. clause states otherwise, the seller assumes transportation and related charges either by payment or allowance.

VIII. PATENT INDEMNITY

The contractor guarantees to hold the County, its agents, officers or employees harmless from liability of any nature or kind for use of any copyrighted or uncopyrighted composition, secret process, patented or unpatented invention, articles or appliances furnished or used in the performance of the contract, for which the contractor is not the patentee, assignee or licensee.

IX. BID BONDS AND PAYMENT AND PERFORMANCE BONDS (IF REQUIRED, FORMS WILL BE PROVIDED IN THIS DOCUMENT)

A five percent (5%) bid bond, a one hundred percent (100%) performance bond, and a one hundred percent (100%) payment bond must be furnished to Gwinnett County for any bid as required in bid package or document. **Failure to submit a bid bond with the proper rating will result in the bid being deemed non-responsive.** Bonding company must be authorized to do business in Georgia by the Georgia Insurance Commission, listed in the Department of the Treasury's publication of companies holding certificates of authority as acceptable surety on Federal bonds and as acceptable reinsuring companies, and have an A.M. Best rating as stated in the insurance requirement of the solicitation. **The bid bond, payment bond, and performance bond must have the proper an A.M. Best rating as stated in the bid when required in the bid package or document.**

X. DISCOUNTS

- A. Time payment discounts will be considered in arriving at net prices and in award of bids. Offers of discounts for payment within ten (10) days following the end of the month are preferred.
- B. In connection with any discount offered, time will be computed from the date of delivery and acceptance at destination, or from the date correct invoice or voucher is received, whichever is the later date. Payment is deemed to be made for the purpose of earning the discount, on the date of the County check.

XI. AWARD

- A. Award will be made to the lowest responsive and responsible bidder. The quality of the articles to be supplied, their conformity with the specifications, their suitability to the requirements of the County, and the delivery terms will be taken into consideration in making the award. The County may make such investigations as it deems necessary to determine the ability of the bidder to perform, and the bidder shall furnish to the County all such information and data for this purpose as the County may request. The County reserves the right to reject any bid if the evidence submitted by, or investigation of such bidder fails to satisfy the County that such bidder is properly qualified to carry out the obligations of the contract.
- B. The County reserves the right to reject or accept any or all bids and to waive technicalities, informalities and minor irregularities in bids received.
- C. The County reserves the right to make an award as deemed in its best interest, which may include awarding a bid to a single bidder or multiple bidders; or to award the whole bid, only part of the bid, or none of the bid to single or multiple bidders, based on its sole discretion of its best interest.

XII. DELIVERY FAILURES

Failure of a contractor to deliver within the time specified or within reasonable time as interpreted by the Purchasing Director, or failure to make replacement of rejected articles/services when so requested, immediately or as directed by the Purchasing Director, shall constitute authority for the Purchasing Director to purchase in the open market articles/services of comparable grade to replace the articles/services rejected or not delivered. On all such purchases, the contractor shall reimburse the County within a reasonable time specified by the Purchasing Director for any expense incurred in excess of contract prices, or the County shall have the right to deduct such amount from monies owed the defaulting contractor. Alternatively, the County may penalize the contractor one percent (1%) per day for a period of up to ten (10) days for each day that delivery or replacement is late. Should public necessity demand it, the County reserves the right to use or consume articles delivered which are substandard in quality, subject to an adjustment in price to be determined by the Purchasing Director.

XIII. COUNTY FURNISHED PROPERTY

No material, labor or facilities will be furnished by the County unless so provided in the invitation to bid.

XIV. REJECTION AND WITHDRAWAL OF BIDS

Failure to observe any of the instructions or conditions in this invitation to bid may constitute grounds for rejection of bid.

XV. CONTRACT

Each bid is received with the understanding that the acceptance in writing by the County of the offer to furnish any or all of the commodities or services described therein shall constitute a contract between the bidder and the County which shall bind the bidder on his part to furnish and deliver the articles quoted at the prices stated in accordance with the conditions of said accepted bid. The County, on its part, may order from such contractor, except for cause beyond reasonable control, and to pay for, at the agreed prices, all articles specified and delivered.

Upon receipt of a bid package containing a Gwinnett County "Sample Contract" as part of the requirements, it is understood that the bidder has reviewed the documents with the understanding that Gwinnett County requires that all agreements between the parties must be

entered into via this document. If any exceptions are taken to any part, each must be stated in detail and submitted as part of the bid. If no exceptions are stated, it is assumed that the bidder fully agrees to the provisions contained in the "Sample Contract" in its entirety.

Any Consultant as defined in O.C.G.A. §36-80-28 that is engaged to develop or draft specifications/requirements or serve in a consultative role during the procurement process for any County procurement method, , by entering into such an arrangement or executing a contract that the consultant agrees to: (1) Avoid any appearance of impropriety and shall follow all policies and procedures of the County (2) disclose to the County, any material transaction or relationship pursuant to §36-80-28, considered a conflict of interest, any involvement in litigation or other dispute, relationship or financial interest not disclosed in the ethics affidavit, when ethics affidavit is required or such that may be discovered during the pending contract or arrangement; and (3) Acknowledge that any violation or threatened violation of the agreement may cause irreparable injury to the County, entitling the County, to seek injunctive relief in addition to all other legal remedies. This requirement does not apply to confidential economic development activities pursuant to §50-18-72 or to any development authority for the purpose of promoting the development of trade, commerce, industry, and employment opportunities or for other purposes and, without limiting the generality of the foregoing, shall specifically include all authorities created pursuant to Title 36 Chapter 62; However, per provisions of subparagraph (e)(1)(B) of Code Section 36-62-5 reporting of potential conflicts of interest by development authority board members is required.

When the contractor has performed in accordance with the provisions of this agreement, Gwinnett County shall pay to the contractor, within thirty (30) days of receipt of any department approved payment request and based upon work completed or service provided pursuant to the contract, the sum so requested, less the retainage stated in this agreement, if any. In the event that Gwinnett County fails to pay the contractor within sixty (60) days of receipt of a pay requested based upon work completed or service provided pursuant to the contract, the County shall pay the contractor interest at the rate of ½% per month or pro rata fraction thereof, beginning the sixty-first (61st) day following receipt of pay requests. The contractor's acceptance of progress payments or final payment shall release all claims for interest on said payment.

XVI. NON-COLLUSION

Bidder declares that the bid is not made in connection with any other bidder submitting a bid for the same commodity or commodities, and that the bid is bona fide and is in all respects fair and without collusion or fraud. An affidavit of non-collusion shall be executed by each bidder. Collusion and fraud in bid preparation shall be reported to the State of Georgia Attorney General and the United States Justice Department.

XVII. DEFAULT

The contract may be canceled or annulled by the Purchasing Director in whole or in part by written notice of default to the contractor upon non-performance or violation of contract terms. An award may be made to the next low responsive and responsible bidder, or articles specified may be purchased on the open market similar to those so terminated. In either event, the defaulting contractor (or his surety) shall be liable to the County for costs to the County in excess of the defaulted contract prices; provided, however, that the contractor shall continue the performance of this contract to the extent not terminated under the provisions of this clause. Failure of the contractor to deliver materials or services within the time stipulated on his bid, unless extended in writing by the Purchasing Director, shall constitute contract default.

XVIII. TERMINATION FOR CAUSE

The County may terminate this agreement for cause upon ten days prior written notice to the contractor of the contractor's default in the performance of any term of this agreement. Such termination shall be without prejudice to any of the County's rights or remedies by law.

XIX. TERMINATION FOR CONVENIENCE

The County may terminate this agreement for its convenience at any time upon 30 days written notice to the contractor. In the event of the County's termination of this agreement for convenience, the contractor will be paid for those services actually performed. Partially completed performance of the agreement will be compensated based upon a signed statement of completion to be submitted by the contractor, which shall itemize each element of performance.

XX. DISPUTES

Except as otherwise provided in the contract documents, any dispute concerning a question of fact arising under the contract which is not disposed of shall be decided after a hearing by the Purchasing Director, who shall reduce his/her decision to writing and mail or otherwise furnish a copy thereof to the contractor. The decision of the procurement agent shall be final and binding; however, the contractor shall have the right to appeal said decision to a court of competent jurisdiction.

XXI. SUBSTITUTIONS

Bidders offering and quoting on substitutions or who are deviating from the attached specifications shall list such deviations on a separate sheet to be submitted with their bid. The absence of such a substitution list shall indicate that the bidder has taken no exception to the specifications contained herein.

XXII. INELIGIBLE BIDDERS

The County may choose not to accept the bid of a bidder who is in default on the payment of taxes, licenses or other monies due to the County. Failure to respond to three (3) consecutive times for any given commodity/service may result in removal from the supplier list under that commodity/service.

XXIII. OCCUPATION TAX CERTIFICATE

Each successful bidder shall provide evidence of a valid Gwinnett County occupation tax certificate if the bidder maintains an office within the unincorporated area of Gwinnett County. Incorporated, out of County, and out of State bidders are required to provide evidence of a certificate to do business in any town, County or municipality in the State of Georgia, or as otherwise required by County ordinance or resolution.

XXIV. PURCHASING POLICY AND REVIEW COMMITTEE

The Purchasing Policy and Review Committee has been established to review purchasing procedures and make recommendations for changes; resolve problems regarding the purchasing process; make recommendations for standardization of commodities, schedule buying, qualified products list, annual contracts, supplier performance (Ineligible Source List), and other problems or requirements related to Purchasing. The Purchasing Policy & Review Committee has authority to place suppliers and contractors on the Ineligible Source List for reasons listed in Part 6, Section II of the Gwinnett County Purchasing Ordinance.

XXV. AMERICANS WITH DISABILITIES ACT

All contractors for Gwinnett County are required to comply with all applicable sections of the Americans with Disabilities Act (ADA) as an equal opportunity employer. In compliance with the Americans with Disabilities Act (ADA), Gwinnett County provides reasonable accommodations to permit a qualified applicant with a disability to enjoy the privileges of employment equal to those employees with disabilities. Disabled individuals must satisfy job requirements for education background, employment experience, and must be able to perform those tasks that are essential to the job with or without reasonable accommodations. Any requests for the reasonable accommodations required by individuals to fully participate in any open meeting, program or activity of Gwinnett County should be directed to Susan Canon, ADA Coordinator, 75 Langley Drive, Lawrenceville, Georgia 30046, 770-822-8165.

XXVI. ALTERATIONS OF SOLICITATION AND ASSOCIATED DOCUMENTS

Alterations of County documents are strictly prohibited and will result in automatic disqualification of the firm's solicitation response. If there are "exceptions" or comments to any of the solicitation requirements or other language, then the firm may make notes to those areas, but may not materially alter any document language.

XXVII. TAX LIABILITY

Local and state governmental entities must notify contractors of their use tax liability on public works projects. Under Georgia law, private contractors are responsible for paying a use tax equal to the sales tax rate on material and equipment purchased under a governmental exemption that is incorporated into a government construction project: excluding material and equipment provided for the installation, repair, or expansion of a public water, gas or sewer system when the property is installed for general distribution purposes. To the extent the tangible personal property maintains its character (for example the installation of a kitchen stove), it remains tax-exempt. However, if the installation incorporates the tangible personal property into realty, e.g., the installation of sheetrock, it becomes taxable to the private contractor. See O.C.G.A. 48-8-3(2) and O.C.G.A. 48-8-63

XXVIII. STATE LAW REGARDING WORKER VERIFICATION

Effective July 1, 2013 State Law requires that all who enter into a contract for the physical performance of services for all labor or service contract(s) that exceed \$2,499.99 (except for services performed by an individual who is licensed pursuant to Title 26, Title 43, or the State Bar of Georgia) for the County, must satisfy the Illegal Immigration Reform Enhancements for 2013, in all manner, and such are conditions of the contract.

The Purchasing Division Director with the assistance of the Performance Analysis Division shall be authorized to conduct random audits of a contractor's or subcontractors' compliance with the Illegal Immigration Reform Enhancements for 2013 and the rules and regulations of the Georgia Department of Labor. The contractor and subcontractors shall retain all documents and records of its compliance for a period of five (5) years following completion of the contract. This requirement shall apply to all contracts for all labor or service contracts that exceed \$2,499.99 except for services performed by an individual who is licensed pursuant to Title 26, Title 43, or the State Bar of Georgia.

Whenever it appears that a contractor's or subcontractor's records are not sufficient to verify the work eligibility of any individual in the employ of such contractor or subcontractor, the Purchasing Director shall report same to the Department of Homeland Security and may result in termination of the contract if it is determined at any time during the work that the contractor/or subcontractor is no longer in compliance with the Illegal Immigration Reform

Enhancements for 2013.

State Law requires that all who enter into a contract for public works as defined by O.C.G.A. 36-91-2(10) for the County must satisfy the Illegal Immigration Reform Enhancements for 2013, in all manner, and such are conditions of the contract.

By submitting a bid to the County, contractor agrees that, in the event the contractor employs or contracts with any subcontractor(s) in connection with the covered contract, the contractor will secure from the subcontractor(s) such subcontractor(s)' indication of the employee-number category applicable to the subcontractor, as well as attestation(s) from such subcontractor(s) that they are in compliance with the Illegal Immigration Reform Enhancements for 2013. Original signed, notarized Subcontractor Affidavits and Agreements must be submitted to the County.

The Purchasing Division Director with the assistance of the Performance Analysis Division shall be authorized to conduct random audits of a contractor's or subcontractors' compliance with the Illegal Immigration Reform Enhancements for 2013 and the rules and regulations of the Georgia Department of Labor. The contractor and subcontractors shall retain all documents and records of its compliance for a period of three (3) years following completion of the contract. This requirement shall apply to all contracts for the public works as defined by O.C.G.A. 36-91-2(10) where any persons are employed on the County contract.

Whenever it appears that a contractor's or subcontractor's records are not sufficient to verify the work eligibility of any individual in the employ of such contractor or subcontractor, the Purchasing Director shall report same to the Department of Homeland Security.

A contractor's failure to participate in the federal work authorization program as defined by the Illegal Immigration Reform Enhancements for 2013 shall be sanctioned by termination of the contract. If it is determined that a subcontractor is not participating in the federal work authorization program as defined by the Illegal Immigration Reform Enhancements for 2013, Gwinnett County may direct the contractor to terminate that subcontractor. A contractor's failure to follow Gwinnett County's instruction to terminate a subcontractor that is not participating in the federal work authorization program as defined by the Illegal Immigration Reform Enhancements for 2013 may be sanctioned by termination of the contract.

XXIX. SOLID WASTE ORDINANCE

No individual, partnership, corporation or other entity shall engage in solid waste handling except in such a manner as to conform to and comply with the current Gwinnett County Solid Waste Ordinance and all other applicable local, state and federal legislation, rules, regulation and orders.

XXX. GENERAL CONTRACTORS LICENSE

Effective July 1, 2008: All General Contractors must have a current valid license from the State Licensing Board for Residential and General Contractors, unless specifically exempted from holding such license pursuant to Georgia law (O.C.G.A. Section 43-41-17).

XXIX. PRODUCTS MANUFACTURED IN GEORGIA

Gwinnett County, when contracting for or purchasing supplies, materials, equipment, or agricultural products that exceeds \$100,000.00, excluding beverages for immediate consumption, shall give preference as far as may be reasonable and practicable to such supplies, materials, equipment, and agricultural products as may be manufactured or produced

in this state. Such preference shall not sacrifice quality. Gwinnett County Board of Commissioners shall consider, among other factors, information submitted by the bidder which may include the bidder's estimate of the multiplier effect on gross state domestic product and the effect on public revenues of the state and the effect on public revenues of political subdivisions resulting from acceptance of a bid or offer to sell Georgia manufactured or produced goods as opposed to out-of-state manufactured or produced goods. Any such estimates shall be in writing. **(O.C.G.A. Section 36-84-1).**

XXXI. INDEMNIFICATION

To the fullest extent permitted by law, the Contractor shall, at his sole cost and expense, indemnify, defend, satisfy all judgments, and hold harmless the County, the engineer, and their agents and employees from and against all claims, damages, actions, judgments, costs, penalties, liabilities, losses and expenses, including, but not limited to, attorney's fees arising out of or resulting from the performance of the work, provided that any such claim, damage, action, judgment, cost, penalty, liability, loss or expense (1) is attributable to bodily injury, sickness, disease, or death, or to injury to or destruction of tangible property (other than the work itself) including the loss of use resulting therefrom, and (2) is caused in whole or in part by the negligent acts, errors by any act or omission of the Contractor, any subcontractor, anyone directly or indirectly employed by any of them or anyone for whose acts any of them may be liable, regardless whether such claim is caused in part by a party indemnified hereunder. Such obligation shall not be construed to negate, abridge or otherwise reduce any of the rights or obligations of indemnity which would otherwise exist as to any party or person described in this agreement. In any and all claims against the County, the engineer, or any of their agents or employees by any employee of the Contractor, any subcontractor, anyone directly or indirectly employed by any of them, or anyone for whose acts any of them may be liable, the indemnification obligation contained herein shall not be limited in any way by any limitation on the amount or type of damages, compensation, or benefits payable by or for the Contractor or any subcontractor under Worker's Compensation Acts, disability benefit acts, or other employee benefit acts.

XXXII. CODE OF ETHICS:

"Proposer/Bidder" shall disclose under oath the name of all elected officials whom it employs or who have a direct or indirect pecuniary interest in the business entity, its affiliates, or its subcontractors. The "Proposer/Bidder" shall execute a Code of Ethics affidavit. Failure to submit the affidavit during the bid or proposal process shall render the bid or proposal non-responsive.

The act of submitting false information or omitting material information shall be referred to the Purchasing Policy & Review Committee for action pursuant to the Purchasing Ordinance or to the District Attorney for possible criminal prosecution.

Any business entity holding a contract with Gwinnett County that subsequent to execution of the contract or issuance of the purchase order employs, subcontracts with, or transfers a direct or indirect pecuniary interest in the business entity to an elected official shall within five (5) days disclose such fact in writing under oath to the Clerk of the Board of Commissioners. Failure to comply shall be referred to the Purchasing Policy & Review Committee for action pursuant to the Purchasing Ordinance or to the District Attorney for possible criminal prosecution.

Note: See Gwinnett County Code of Ethics Ordinance E02011, Sec. 54-33. The ordinance will be available to view in its entirety at www.gwinnettcountry.com.

XXXIII. PENDING LITIGATION:

A bid submitted by an individual, firm or business who has litigation pending against the County, or anyone representing a firm or business in litigation against the County, not arising out of the procurement process, will be disqualified.

XXXIV. ELECTRONIC PAYMENT

Vendors accepting procurements should select one of Gwinnett County's electronic payment options.

- A. A vendor may select ePayables payment process which allows acceptance of Gwinnett County's virtual credit card as payment for outstanding invoices. The authorized vendor representative must send an email to: vendorelectronicpayment@gwinnettcounty.com and indicate the desire to enroll in Gwinnett County's virtual credit card payment process.
- B. A vendor may select Direct Deposit payment process and the payment will be deposited directly into an account at their designated financial institution. To securely enroll in Direct Deposit, either access your online [Vendor Login and Registration](#) on the County's web site and update the requested information on the Direct Deposit tab or mail a Direct Deposit Authorization Agreement form.

The County will send a Payment Advice notification via email for both payment types.

For more information about Electronic Payments, please go to the Treasury Division page on the County's Web Site or click here -> [Gwinnett County Electronic Payments](#).

DIRECTIONS TO GJAC BUILDING FROM I-85

Take I-85 to Georgia Highway 316 (Lawrenceville/Athens exit). Exit Highway 120 (Lawrenceville/Duluth exit) and turn right. At seventh traffic light, turn right onto Langley Drive. Cross Highway 29 through the traffic light and cross at the 4-way stop sign. The main public parking lot is on the left or behind the building, Click [Here](#), for additional information about parking. The Purchasing Division is located in the Administrative Wing.

Attachment A: Project Drawings and Photos



ADJUST WATER VALVE BOX TOP TO MATCH NEW PAVEMENT ELEVATION WITH A RISER RING AS MANUFACTURED BY EJ COMPANY.



MILL AND REPLACE TO MATCH THE NEW PAVEMENT TO EXISTING MANHOLE ELEVATION.



REMOVE AND REPLACE EXISTING CONCRETE COLLAR AROUND MANHOLE TOP. SEE MANHOLE COLLAR DETAIL.



SAWCUT EXISTING DRIVEWAY PAVEMENT USING WIDER ROAD SECTION AS LIMIT OF CUT.



REMOVE EXISTING CONCRETE PATCH. SAWCUT 2'-0" INSIDE OF PATCH AND RECONNECT. REPAVE WITH ASPHALT PAVEMENT AS PER THE PAVEMENT CONNECTION DETAIL.



ADJUST WATER VALVE BOX TOP TO MATCH EXISTING VALVE ELEVATION. ADJUST EXISTING VALVE BOX HEIGHT WITH A RISER RING AS MANUFACTURED BY EJ COMPANY. SAWCUT INTO DRIVEWAY TO REMOVE EXISTING JOINT.



MILL AND REPLACE TO MATCH NEW PAVEMENT TO EXISTING MANHOLE COVER ELEVATION.

SAWCUT EXISTING PAVEMENT

SAWCUT EXISTING PAVEMENT

MILL AND RESURFACE ASPHALT PAVEMENT. SEE TYPICAL RESURFACING DETAIL

SAWCUT EXISTING PAVEMENT AT RADIUS RETURN.

SAWCUT EXISTING PAVEMENT APPROXIMATELY 15-FT INTO THE DRIVEWAY IN ORDER TO REMOVE THE EXISTING JOINT.

MILL AROUND CONCRETE COLLAR WITHOUT DISTURBING. SAWCUT BROKEN EDGE OF CONCRETE AND REPLACE.

MILL DEPTH REQUIRED TO MATCH THE NEW PAVEMENT TO THE EXISTING MANHOLE AND CONCRETE COLLAR ELEVATION.

MILL AND REPLACE TO MATCH THE NEW PAVEMENT TO EXISTING MANHOLE ELEVATION.

ADJUST WATER VALVE BOX TOP TO MATCH NEW PAVEMENT ELEVATION. ADJUST EXISTING VALVE BOX HEIGHT WITH A RISER RING AS MANUFACTURED BY EJ COMPANY.

SAWCUT EXISTING PAVEMENT INTO THE DRIVEWAY BEYOND THE EXISTING JOINT.

MILL AND REPLACE TO MATCH THE NEW PAVEMENT TO EXISTING MANHOLE ELEVATION.

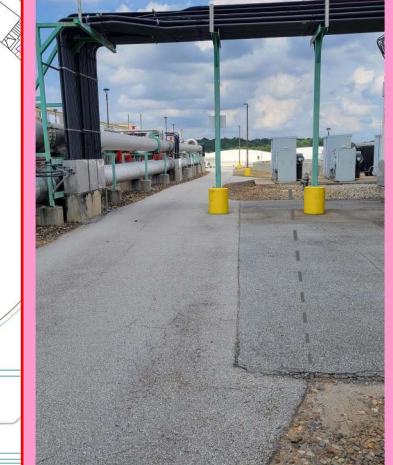
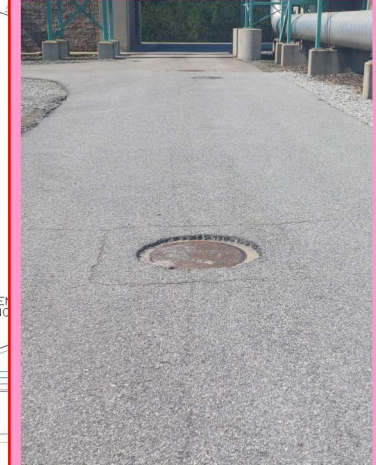



RELOCATE "RECLAIMED WATER FILL STATION" SIGN 4'-0" OUTSIDE OF PROPOSED PAVEMENT WIDENING. SEE SIGN PLACEMENT DETAIL

SAWCUT 2'-0" INSIDE OF EXISTING EDGE OF PAVEMENT TO CONNECT PAVEMENT AREA TO BE WIDENED TO EXISTING PAVEMENT. SEE PAVEMENT CONNECTION DETAIL

ASPHALT PAVEMENT, SEE ASPHALT PAVEMENT DETAIL

SAWCUT FROM THE EDGE OF PAVEMENT AT THE WATER BOX UNTIL THE EXISTING JOINT AND REPLACE WITH NEW ASPHALT WIDENING AS SHOWN. SEE PHOTO.

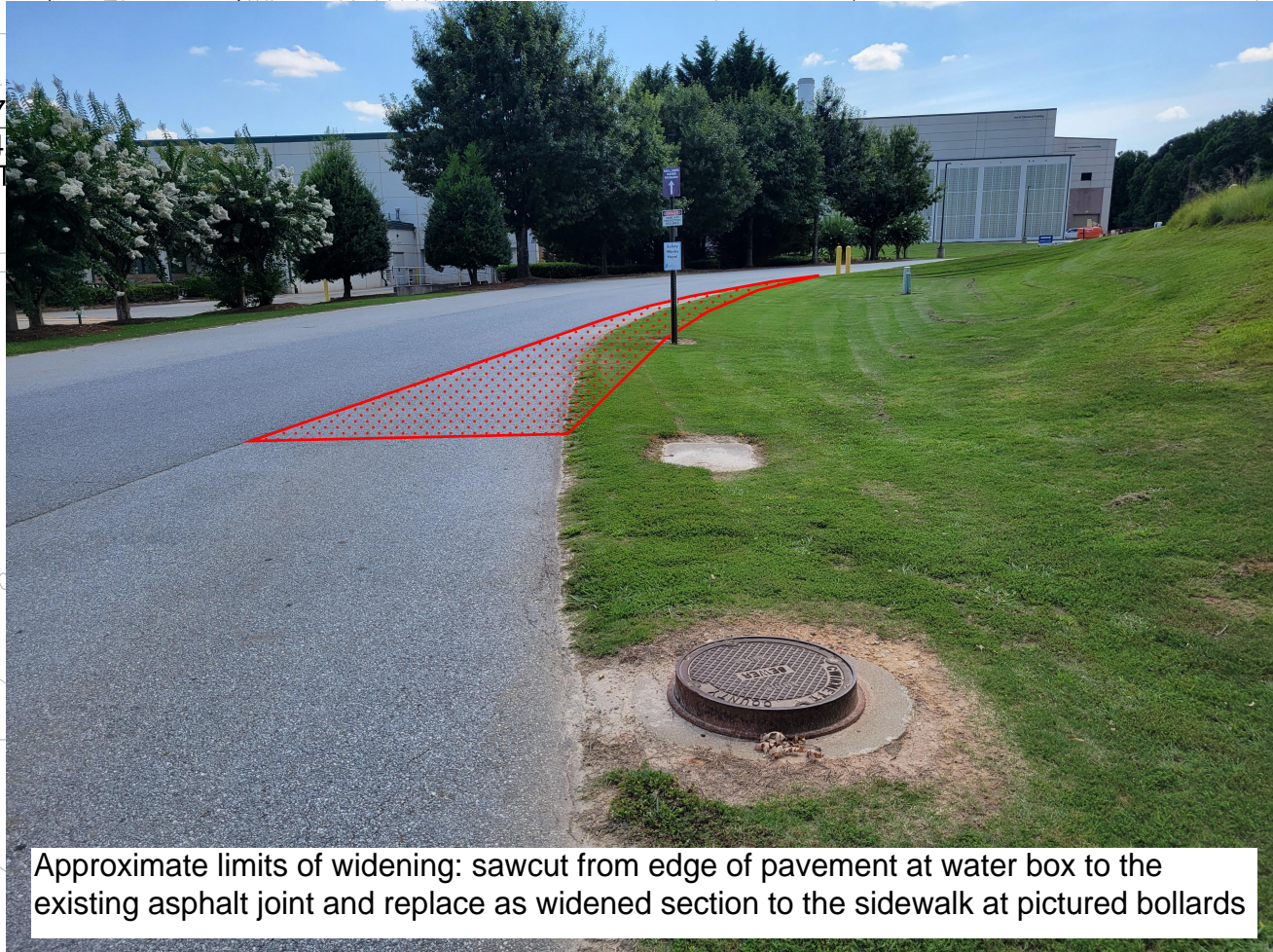

Approximate limits of widening: sawcut from edge of pavement at water box to the existing asphalt joint and replace as widened section to the sidewalk at pictured bollards

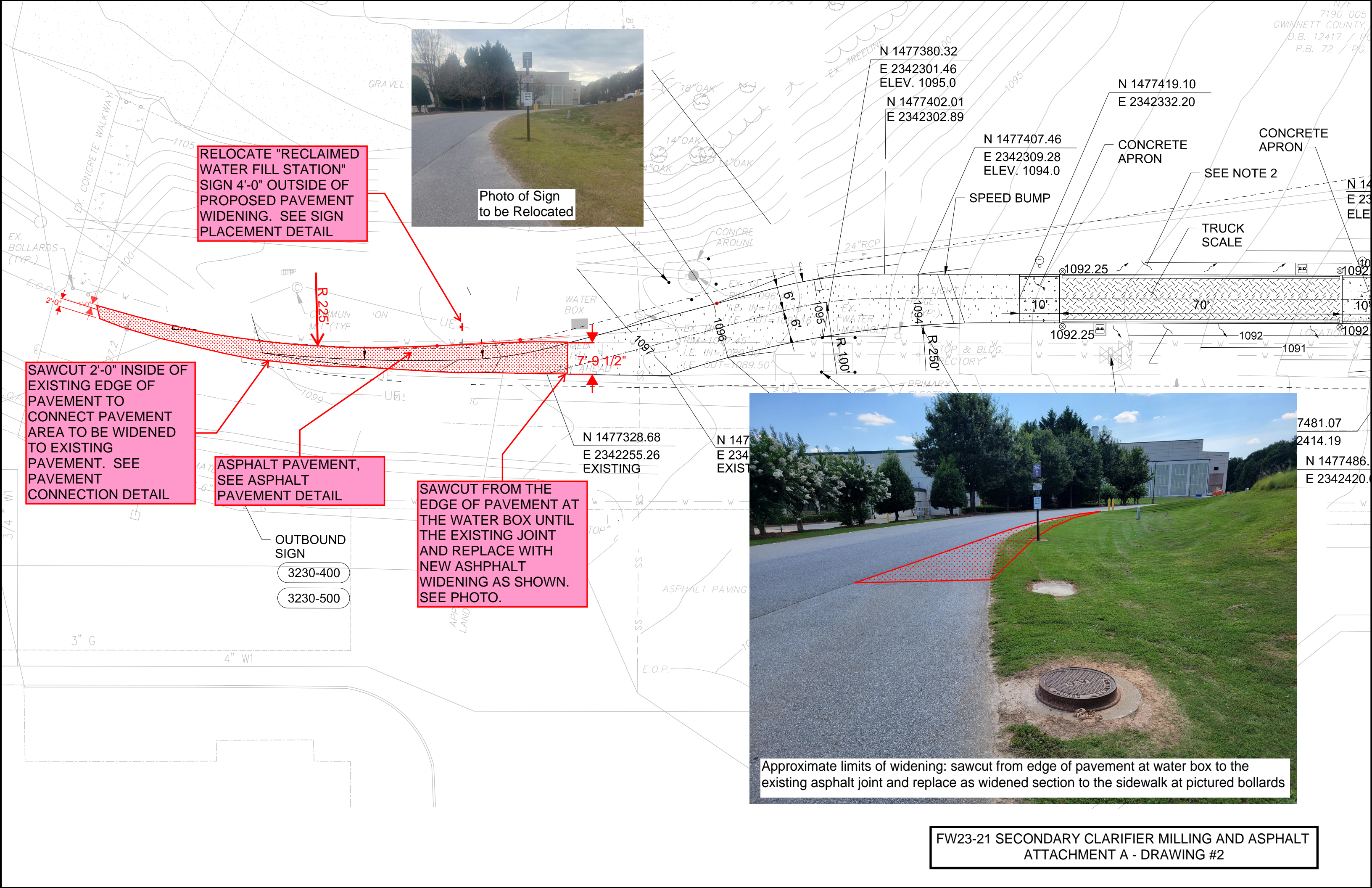

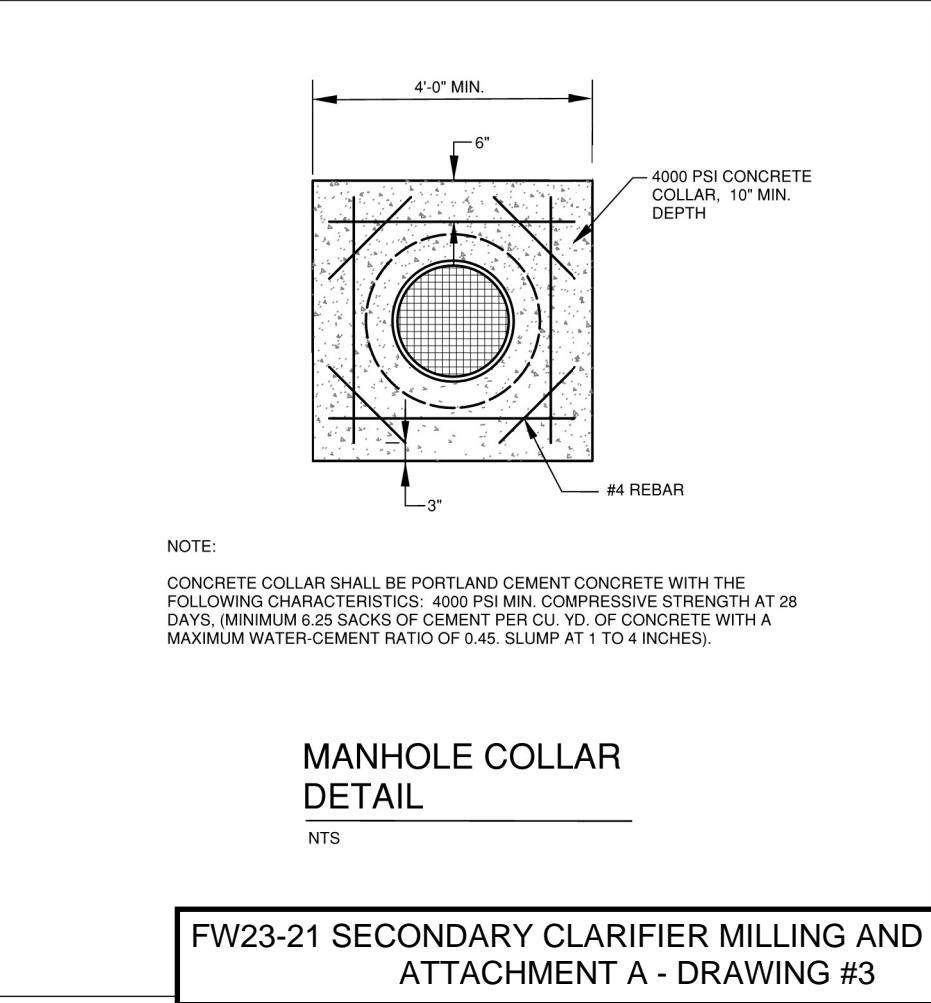
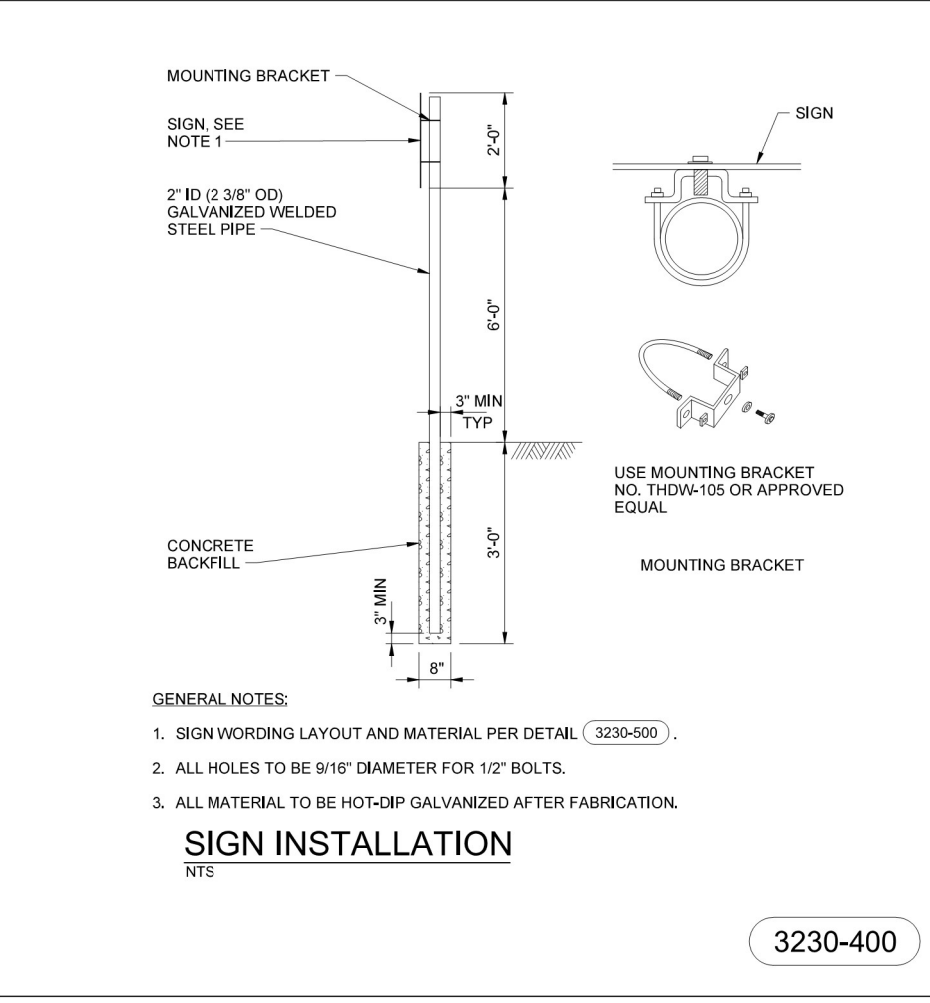
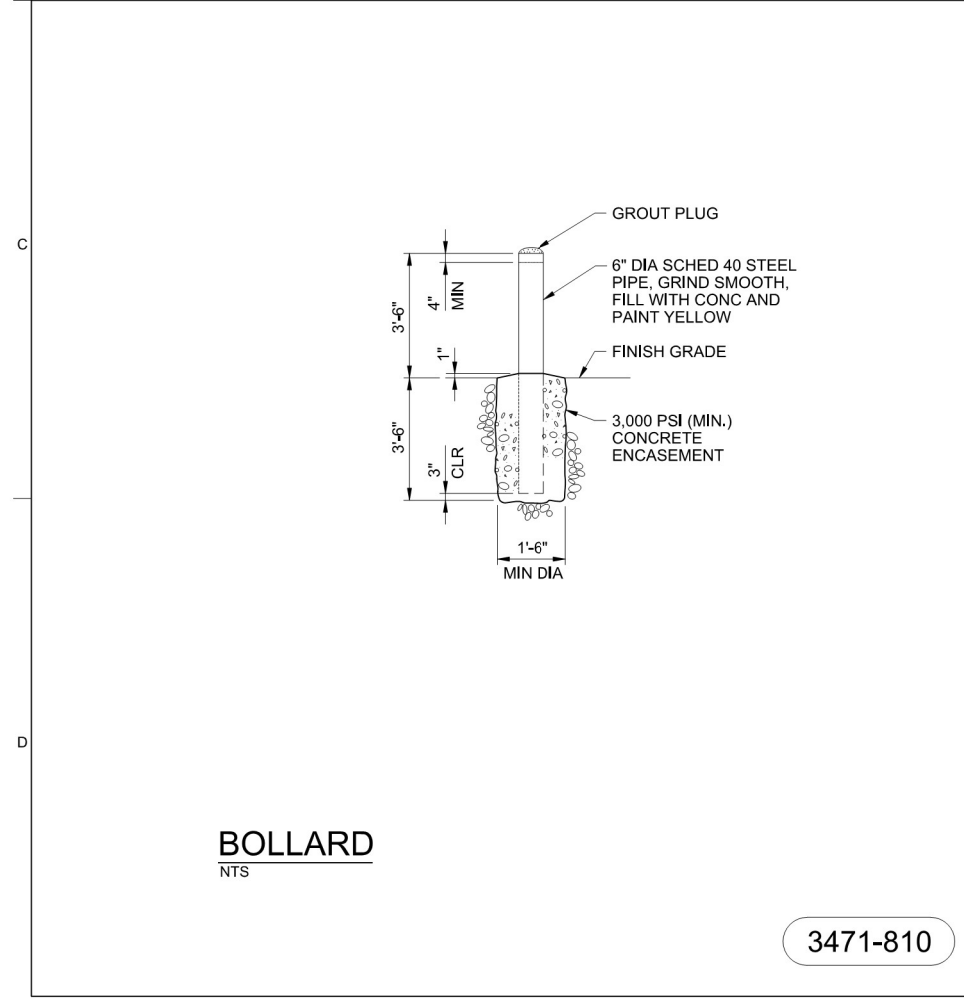
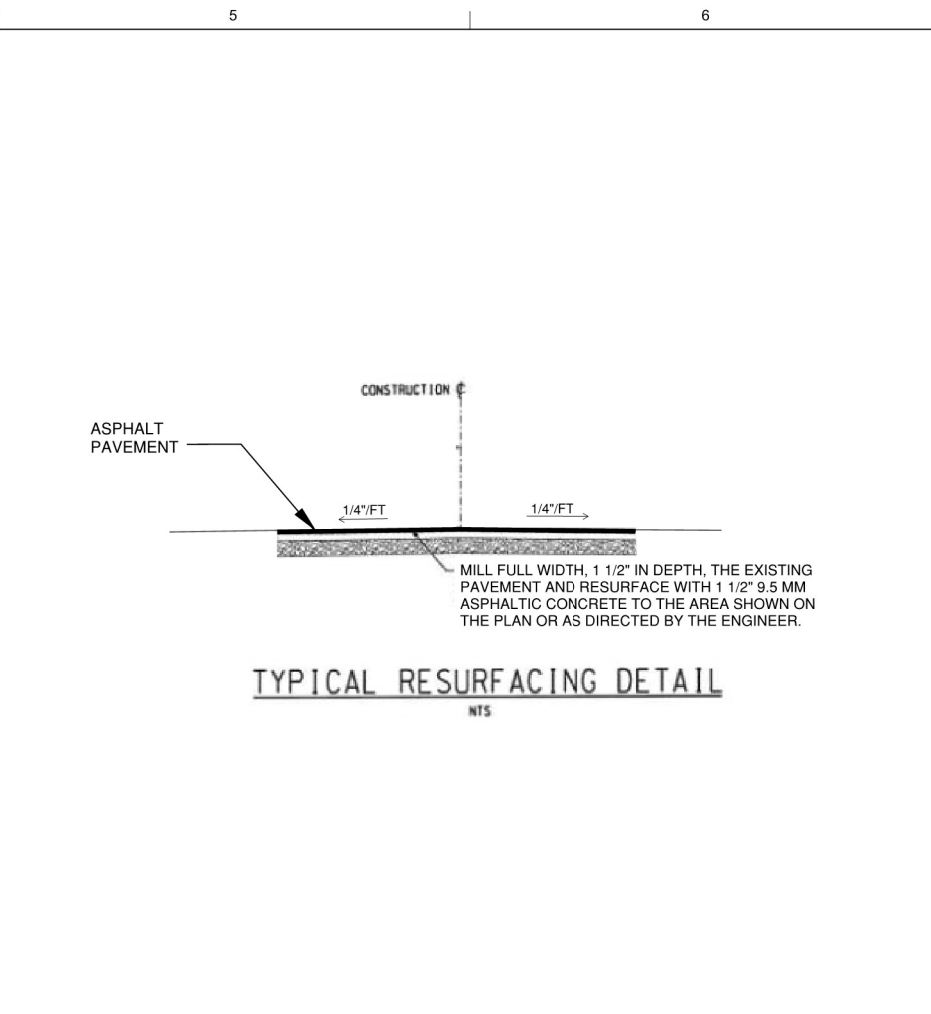
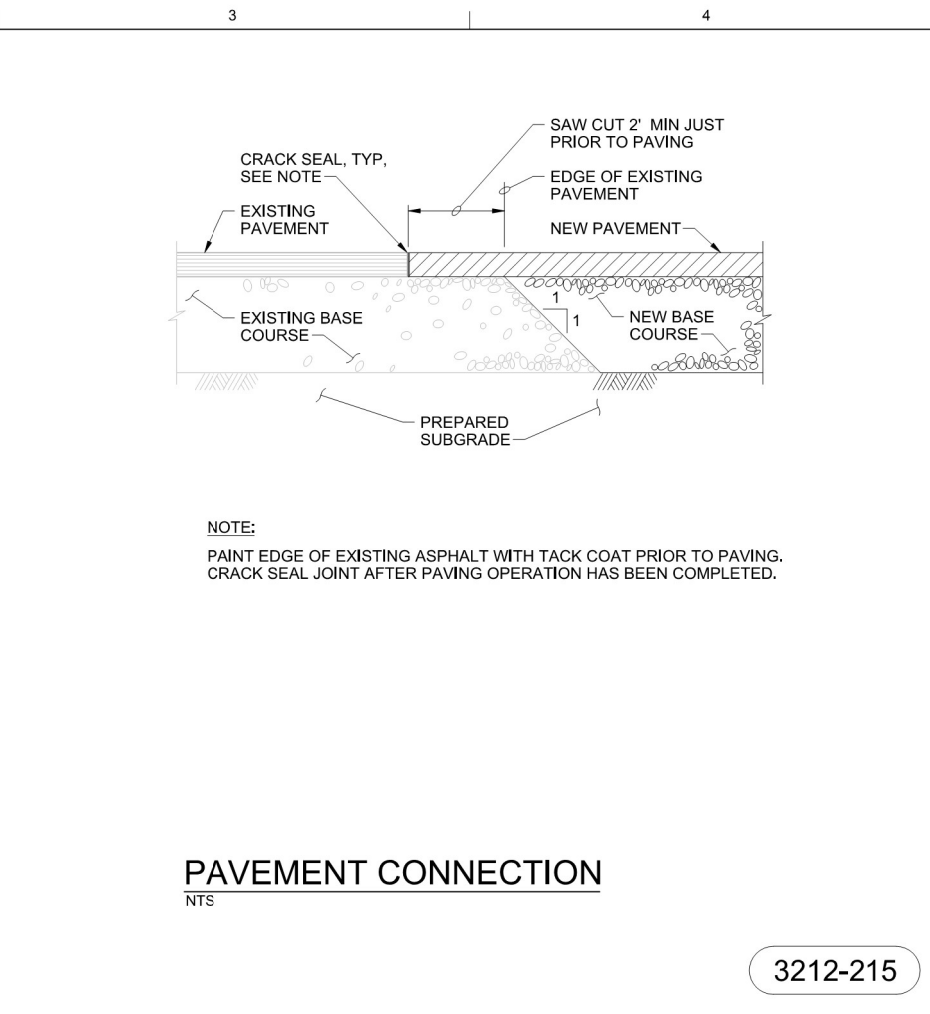
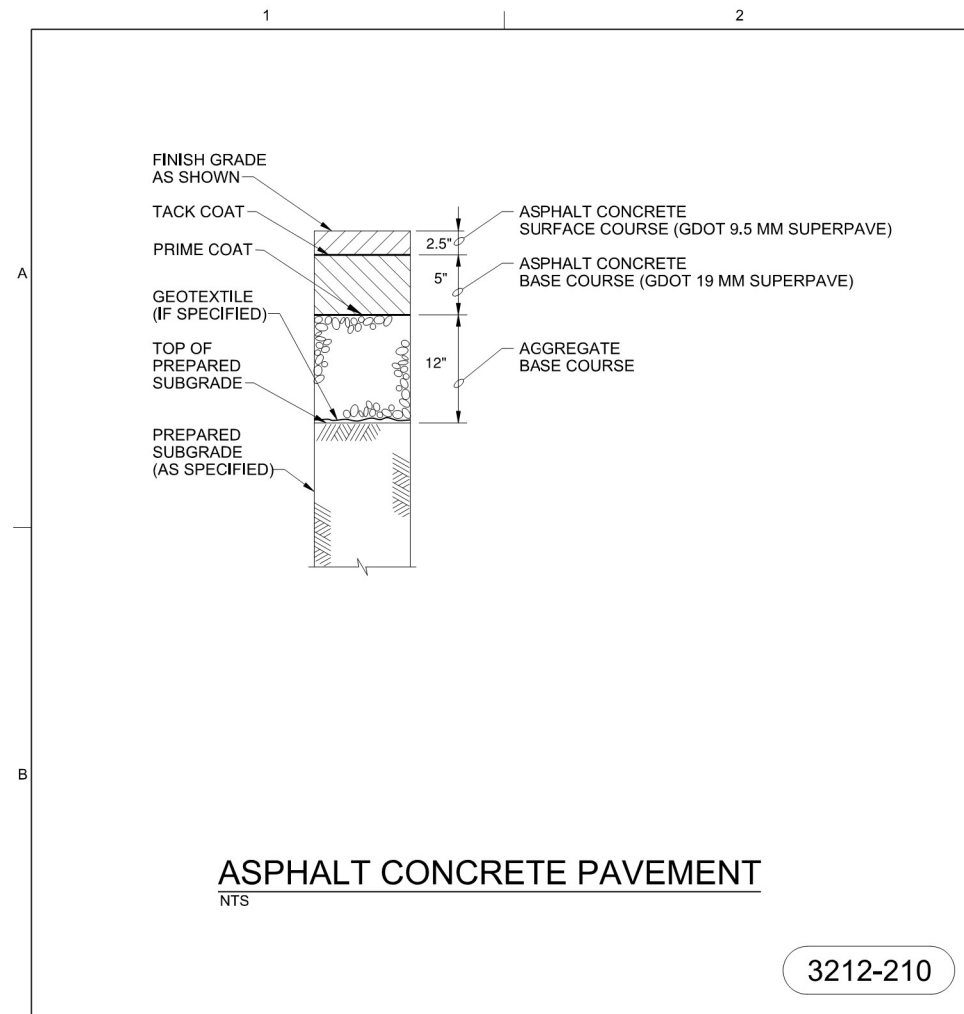

Attachment B: Project Specifications

SECTION 32 12 16
ASPHALT PAVING

PART 1 GENERAL

1.01 REFERENCES

- A. The following is a list of standards which may be referenced in this section:
1. American Association of State Highway and Transportation Officials (AASHTO):
 - a. M17, Standard Specification for Mineral Filler for Bituminous Paving Mixtures.
 - b. M81, Standard Specification for Cut-Back Asphalt (Rapid Curing Type).
 - c. M82, Standard Specification for Cut-Back Asphalt (Medium Curing Type).
 - d. M140, Standard Specification for Emulsified Asphalt.
 - e. M156, Standard Specification for Requirements for Mixing Plants for Hot-mixed, Hot-laid Bituminous Paving Mixes.
 - f. M208, Standard Specification for Cationic Emulsified Asphalt.
 - g. R35, Standard Practice for Superpave Volumetric Design for Hot Mix Asphalt.
 - h. T166, Standard Method of Test for Bulk Specific Gravity (Gmb) of Compacted Hot Mix Asphalt (HMA) Mixtures Using Saturated Surface-Dry Specimens.
 - i. T176 Standard Method of Test for Plastic Fines in Graded Aggregates and Soils by Use of the Sand Equivalent Test.
 - j. T209, Standard Method of Test for Theoretical Maximum Specific Gravity (Gmm) and Density of Hot Mix Asphalt (HMA).
 - k. T245, Standard Method of Test for Resistance to Plastic Flow of Asphalt Mixtures Using Marshall Apparatus.
 - l. T246, Standard Method of Test for Resistance to Deformation and Cohesion of Hot Mix Asphalt (HMA) by Means of Hveem Apparatus.
 - m. T247, Standard Method of Test for Preparation of Test Specimens of Hot Mix Asphalt (HMA) by Means of California Kneading Compactor.
 - n. T283, Standard Method of Test for Resistance of Compacted Hot Mix Asphalt (HMA) to Moisture-Induced Damage.
 - o. T304, Standard Method of Test for Uncompacted Void Content of Fine Aggregate.
 - p. T312, Standard Method of Test for Preparing and Determining the Density of Hot Mix Asphalt (HMA) Specimens by Means of a Superpave Gyrotory Compactor.
 2. Asphalt Institute (AI):

FW23-21 Secondary Clarifier Milling, Paving & Road Addition

- a. Manual Series No. 2 (MS-2), Mix Design Methods for Asphalt Concrete.
- b. Superpave Series No. 2 (SP-2), Superpave Mix Design.
3. ASTM International (ASTM):
 - a. D75, Standard Method of Test for Sampling of Aggregates.
 - b. D140, Standard Method of Test for Sampling Bituminous Materials.
 - c. D979, Standard Method of Test for Sampling Bituminous Paving Mixtures.
 - d. D2041, Standard Test Method for Theoretical Maximum Specific Gravity and Density of Bituminous Paving Mixtures.
 - e. D2489, Standard Method of Test for Determining Degree of Particle Coating of Asphalt Mixtures.
 - f. D4318, Standard Test Methods for Liquid Limit, Plastic Limit, and Plasticity Index of Soils.
 - g. D4791, Standard Test Method for Flat Particles, Elongated Particles, or Flat and Elongated Particles in Coarse Aggregate.
 - h. D5821, Standard Test Method for Determining the Percentage of Fractured Particles in Coarse Aggregate.
 - i. E329 REV A, Standard Specification for Agencies Engaged in Construction Inspection Testing, or Special Inspection.

1.02 DEFINITIONS

- A. Combined Aggregate: All mineral constituents of asphalt concrete mix, including mineral filler and separately sized aggregates.
- B. Maximum Aggregate Size: One sieve size larger than the nominal aggregate size.
- C. Nominal Aggregate Size: One sieve size larger than the first sieve that retains more than 10 percent aggregate.
- D. Prime Coat: Low viscosity cutback or emulsified asphalt applied to granular base in preparation of paving to coat and bond loose materials, harden the surface, plug voids, prevent moisture migration, and provide adhesion.
- E. Reclaimed asphalt pavement (RAP): Removed and/or processed pavement materials containing binder and aggregate.
- F. Seal Coat: Term used for various applications of emulsified asphalt, with or without sand or aggregate, to protect the asphalt surface from aging due to wear, degradation from the sun, wind, and water. Also used to improve skid resistance and aesthetics. The term seal coat can be used to define fog seal, slurry seal, chip seal or sand seal, depending on application.

- G. Standard Specifications: Georgia Department of Transportation, Standard Specifications for Construction of Roads and Bridges.
- H. Tack Coat: Thin layer of emulsified asphalt applied to hard surfaces, including new pavement lifts, to promote adhesion and bonding.

1.03 DESIGN REQUIREMENTS

- A. Prepare asphalt concrete mix design, meeting the following design criteria, tolerances, and other requirements of this Specification.

1.04 SUBMITTALS

- A. Certificates: Provide certificates stating that materials supplied comply with Specifications. Certificates shall be signed by the asphalt producer and the Contractor.
- B. Mix Design: Submit mix design for each course to the Engineer for acceptance.

1.05 QUALITY ASSURANCE

- A. Qualifications:
 - 1. Independent Testing Laboratory: In accordance with ASTM E329 REV A.
 - 2. Asphalt concrete mix formula shall be prepared by approved certified independent laboratory under the supervision of a certified asphalt technician.

1.06 ENVIRONMENTAL REQUIREMENTS

- A. Temperature: Do not apply asphalt materials or place asphalt mixes when ground temperature is lower than 50 degrees F or air temperature is lower than 40 degrees F. Measure ground and air temperature in shaded areas away from heat sources or wet surfaces.
- B. Moisture: Do not apply asphalt materials or place asphalt mixes when application surface is wet.

PART 2 PRODUCTS

2.01 MATERIALS

- A. Graded Aggregate Base: Graded aggregate base course shall be of uniform quality throughout and shall meet the requirements of Section 815.01 of the Georgia Department of Transportation Standard Specifications.

- B. Base Course: Base course shall be uniform quality throughout and shall meet the requirements of Section 828 of the Georgia Department of Transportation Standard Specifications.
- C. Binder Course: Binder course shall be of uniform quality throughout and shall conform to the requirements of Section 828, 19 mm Superpave, Type “B-Modified” of the Georgia Department of Transportation Standard Specifications.
- D. Surface Course: Surface course shall be of uniform quality throughout and shall conform to the requirements of Section 828, 12.5 mm Superpave of the Georgia Department of Transportation Standard Specifications.
- E. Prime Coat: Prime coat shall conform to the requirements of Section 412 of the Georgia Department of Transportation Standard Specifications.
- F. Tack Coat: Tack coat shall conform to the requirements of Section 413 of the Georgia Department of Transportation Standard Specifications.

PART 3 EXECUTION

3.01 GENERAL

- A. Traffic Control: Minimize inconvenience to traffic, but keep vehicles off freshly treated or paved surfaces to avoid pickup and tracking of asphalt.

3.02 LINE AND GRADE

- A. Provide and maintain intermediate control of line and grade, independent of underlying base, to meet finish surface grades and minimum thickness.
- B. Shoulders: Construct to line, grade, and cross-section shown.

3.03 SURFACE PREPARATION

- A. Graded Aggregate Base Course:
 - 1. Check subgrade for conformity with elevations and section immediately before placing aggregate base material.
 - 2. Place aggregate base material in compacted layers not more than 6-inches thick, unless continuing tests indicate that the required results are being contained with thicker layers.
 - 3. In no case shall more than 8-inches of compacted base be placed in one lift.
 - 4. Spread, shape, and compact all aggregate base material deposited on the subgrade during the same day.

FW23-21 Secondary Clarifier Milling, Paving & Road Addition

5. The compacted base shall have sufficient stability to support construction traffic without pumping.
6. If compacted base becomes unstable as a result of too much moisture, the base material and underlying subgrade, if necessary, shall be dried and reworked to a moisture content that can be recompacted.

B. Existing Roadway:

1. Modify profile by grinding, milling, or overlay methods as approved, to provide meet lines and surfaces and to produce smooth riding connection to existing facility.
2. Remove existing pavement to be overlaid to a minimum depth of 1-1/2 inch.
3. Dispose of waste material offsite in conformance with regulatory requirements.
4. Apply tack coat prior to placing the asphalt concrete.
5. Meet lines shall be straight and the edges vertical.
6. Seal meet line by painting with an emulsified asphalt a minimum of 4 inches on each side of the joint and immediately covered with clean, dry sand after placing asphalt concrete.

C. Loose and Foreign Material:

1. Remove loose and foreign material from surface immediately before application of paving.
2. Use power brooms or blowers, and hand brooming as required.
3. Do not displace surface material.

D. Prime Coat:

1. Uniformly apply at a rate of 0.20 to 0.50 gallon per square yard over compacted and cleaned subbase surface.
2. Apply enough material to penetrate and seal, but not flood the surface.
3. Allow to cure and dry as long as required to attain penetration and evaporation of volatile, and in no case less than 24 hours unless otherwise acceptable to the Engineer.
4. Blot excess asphalt with just enough sand to prevent pick-up under traffic.
5. Remove loose sand before paving.

E. Tack Coat:

1. Dilute material with equal parts of water and apply to contact surfaces of previously constructed asphalt concrete or Portland cement concrete and similar surfaces.
2. Apply at a rate of 0.05 to 0.15 gallon per square yard of surface.

3. Apply tack coat by brush to contact surfaces of curbs, gutters, manholes, and other structures projecting into or abutting asphalt concrete pavement.
4. Allow surfaces to dry until material is at condition of tackiness to receive pavement.

3.04 EQUIPMENT

- A. Provide size and quantity of equipment to complete the work specified within the Project time schedule.
- B. Bituminous pavers shall be self-propelled that spread hot asphalt concrete mixtures without tearing, shoving or gouging surfaces, and control pavement edges to true lines without use of stationary forms.
- C. Rolling equipment shall be self-propelled, steel-wheeled and pneumatic-tired rollers that can reverse direction without backlash.
- D. Provide rakes, lutes, shovels, tampers, smoothing irons, pavement cutters, portable heaters, and other miscellaneous small tools to complete the work specified.

3.05 ASPHALTIC CONCRETE PLACEMENT

- A. Place asphalt concrete mix on prepared surface, spread and strike-off using paving machine.
- B. Spread mixture at a minimum temperature of 325 degrees F with a variance of 20 degrees plus or minus.
- C. Inaccessible and small areas may be placed by hand.
- D. Place each course at a thickness such that when compacted it will conform to the indicated grade, cross-section, finish thickness, and density indicated.
- E. Pavement Placing:
 1. Unless otherwise directed, begin placing along centerline of areas to be paved on crowned section, and at high side of sections on one-way slope, and in direction of traffic flow.
 2. After first strip has been placed and rolled, place succeeding strips and extend rolling to overlap previous strips.
 3. Complete base courses for a section before placing surface courses.
 4. Place mixture in as continuous an operation as practical.
- F. Hand Placing:

FW23-21 Secondary Clarifier Milling, Paving & Road Addition

1. Spread, tamp, and finish mixture using hand tools in areas where machine spreading is not possible, as acceptable to Engineer.
2. Place mixture at a rate that will ensure handling and compaction before mixture becomes cooler than acceptable working temperature.

G. Joints:

1. Carefully make joints between old and new pavements, or between successive days work, to ensure a continuous bond between adjoining work.
2. Construct joints to have same texture, density and smoothness as adjacent sections of asphalt concrete course.
3. Clean contact surfaces free of sand, dirt, or other objectionable material and apply tack coat.
4. Offset transverse joints in succeeding courses not less than 24-inches.
5. Cut back edge of previously placed course to expose an even, vertical surface for full course thickness.
6. Offset longitudinal joints in succeeding courses not less than 6-inches.
7. When the edges of longitudinal joints are irregular, honeycombed, or inadequately compacted, cut back unsatisfactory sections to expose an even, vertical surface for full course thickness.

3.06 ASPHALTIC CONCRETE COMPACTION

- A. Provide sufficient rollers to obtain the required pavement density.
- B. Begin rolling operations as soon after placing as the mixture will bear weight of roller without excessive displacement.
- C. Do not permit heavy equipment, including rollers to stand on finished surface before it has thoroughly cooled or set.
- D. Compact mixture with hot hand tampers or vibrating plate compactors in areas inaccessible to rollers.
- E. Start rolling longitudinally at extreme lower side of sections and proceed toward center of pavement. Roll to slightly different lengths on alternate roller runs.
- F. Do not roll centers of sections first under any circumstances.
- G. Breakdown Rolling:
 1. Accomplish breakdown or initial rolling immediately following rolling of transverse and longitudinal joints and outside edge.
 2. Operate rollers as close as possible to paver without causing pavement displacement.

FW23-21 Secondary Clarifier Milling, Paving & Road Addition

3. Check crown, grade, and smoothness after breakdown rolling.
4. Repair displaced areas by loosening at once with lutes or rakes and filling, if required, with hot loose material before continuing rolling.

H. Second Rolling:

1. Follow breakdown rolling as soon as possible, while mixture is hot and in condition for compaction.
2. Continue second rolling until mixture has been thoroughly compacted.

I. Finish Rolling:

1. Perform finish rolling while mixture is still warm enough for removal of roller marks.
2. Continue rolling until roller marks are eliminated and course has attained specified density.

J. Patching:

1. Remove and replace defective areas.
2. Cut-out and fill with fresh, hot asphalt concrete.
3. Compact by rolling to specified surface density and smoothness.
4. Remove deficient areas for full depth of course.
5. Cut sides perpendicular and parallel to direction of traffic with edges vertical.
6. Apply tack coat to exposed surfaces before placing new asphalt concrete mixture.

3.07 FIELD QUALITY CONTROL

A. General: Provide services of approved certified independent testing laboratory to conduct tests.

B. Field Density Tests:

1. Perform tests from cores or sawed samples in accordance with AASHTO T166.
2. Measure with properly operating and calibrated nuclear density gauge in accordance with ASTM D2950.
3. Maximum Density: In accordance with ASTM D2041, using sample of mix taken prior to compaction from same location as density test sample.

C. Testing Frequency:

1. Quality Control Tests:

FW23-21 Secondary Clarifier Milling, Paving & Road Addition

- a. Asphalt Content, Aggregate Gradation: Once per every 500 tons of mix or once every 4 hours, whichever is greater.
 - b. Mix Design Properties, Measured Maximum (Rice's) Specific Gravity: Once every 1,000 tons or once every 8 hours, whichever is greater.
2. Density Tests: Once every 200 tons of mix or once every 4 hours, whichever is greater.

END OF SECTION

FW23-21 Secondary Clarifier Milling, Paving & Road Addition

SECTION 32 92 00
TURF AND GRASSES

PART 1 GENERAL

1.01 DEFINITIONS

- A. Maintenance Period: Begin maintenance immediately after each area is planted (seed, sod, or sprig) and continue for a period of 8 weeks after all planting under this section is completed.
- B. Satisfactory Stand: No bare spots larger than 3 square feet.
 - 1. Not more than 10 percent of total area with dead sod.

1.02 SUBMITTALS

- A. Action Submittals: Product labels/data sheets.
- B. Informational Submittals:
 - 1. Certification of sod; include source and harvest date of sod, and sod seed mix.
 - 2. Description of required maintenance activities and activity frequency.

1.03 DELIVERY, STORAGE, AND PROTECTION

- A. Sod:
 - 1. Do not harvest if sod is excessively dry or wet to the extent survival may be adversely affected.
 - 2. Harvest and deliver sod only after laying bed is prepared for sodding.
 - 3. Roll or stack to prevent yellowing.
 - 4. Deliver and lay within 24 hours of harvesting.
 - 5. Keep moist and covered to protect from drying from time of harvesting until laid.

1.04 WEATHER RESTRICTIONS

- A. Perform Work under favorable weather and soil moisture conditions as determined by accepted local practice.

1.05 SEQUENCING AND SCHEDULING

- A. Complete Work under this section within 3 days following completion of soil preparation.
- B. Notify Engineer at least 3 days in advance of:
 - 1. Each material delivery.
 - 2. Start of planting activity.
- C. Planting Season: Those times of year that are normal for such Work as determined by accepted local practice.

1.06 MAINTENANCE SERVICE

- A. Contractor: Perform maintenance operations during maintenance period to include:
 - 1. Watering: Keep surface moist.
 - 2. Washouts: Repair by filling with topsoil, liming, fertilizing, seeding, and mulching.
 - 3. Mulch: Replace wherever and whenever washed or blown away.
 - 4. Mowing: Mow to 2 inches after grass height reaches 3 inches, and mow to maintain grass height from exceeding 3-1/2 inches.
 - 5. Reseed unsatisfactory areas or portions thereof immediately at the end of the maintenance period if a satisfactory stand has not been produced.
 - 6. Reseed/replant during next planting season if scheduled end of maintenance period falls after September 15.
 - 7. Reseed/replant entire area if satisfactory stand does not develop by July 1 of the following year.

PART 2 PRODUCTS

2.01 FERTILIZER

- A. Commercial, uniform in composition, free-flowing, suitable for application with equipment designed for that purpose. Minimum percentage of plant food by weight.
- B. Application Rates: Determined by soil analysis results.
- C. Mix:
 - 1. Nitrogen: 10.
 - 2. Phosphoric Acid: 10.
 - 3. Potash: 10.

D. Top Dress Type: As recommended by local authority.

2.02 SOD

A. Certified: Coordinate with Owner and Engineer to match existing grass type.

B. Strongly rooted pads, capable of supporting own weight and retaining size and shape when suspended vertically from a firm grasp on upper 10 percent of pad.

1. Grass Height: Normal.
2. Strip Size: Supplier's standard.
3. Soil Thickness: Uniform; 1 inch plus or minus 1/4 inch at time of cutting.
4. Age: Not less than 10 months or more than 30 months.
5. Condition: Healthy, green, moist; free of diseases, nematodes and insects, and of undesirable grassy and broadleaf weeds. Yellow sod, or broken pads, or torn or uneven ends will not be accepted.

PART 3 EXECUTION

3.01 PREPARATION

A. Grade areas to smooth, even surface with loose, uniformly fine texture.

1. Roll and rake, remove ridges, fill depressions to meet finish grades.
2. Limit such Work to areas to be planted within immediate future.
3. Remove debris, and stones larger than 1-1/2-inch diameter, and other objects that may interfere with planting and maintenance operations.

B. Moisten prepared areas before planting if soil is dry. Water thoroughly and allow surface to dry off before seeding. Do not create muddy soil.

C. Restore prepared areas to specified condition if eroded or otherwise disturbed after preparation and before planting.

3.02 FERTILIZER

A. Apply evenly over area in accordance with manufacturer's instructions. Mix into top 2 inches of topsoil, when applied by broad cast method.

B. Application Rate: Per Manufacturer Instructions.

3.03 SODDING

A. Do not plant dormant sod, or when ground is frozen.

- B. Lay sod to form solid mass with tightly fitted joints; butt ends and sides, do not overlap.
 - 1. Stagger strips to offset joints in adjacent courses.
 - 2. Work from boards to avoid damage to subgrade or sod.
 - 3. Tamp or roll lightly to ensure contact with subgrade; work sifted soil into minor cracks between pieces of sod, remove excess to avoid smothering adjacent grass.
 - 4. Complete sod surface true to finished grade, even, and firm.
- C. Fasten sod on slopes to prevent slippage with wooden pins 6 inches long driven through sod into subgrade, until flush with top of sod. Install at sufficiently close intervals to securely hold sod.
- D. Water sod with fine spray immediately after planting. During first week, water daily or more frequently to maintain moist soil to depth of 4 inches.
- E. Apply top dress fertilizer at recommended rate.

3.04 FIELD QUALITY CONTROL

- A. 8 weeks after seeding is complete and on written notice from Contractor, Engineer will, within 15 days of receipt, determine if a satisfactory stand has been established.
- B. If a satisfactory stand has not been established, Engineer will make another determination after written notice from Contractor following the next growing season.

3.05 PROTECTION

- A. Protect from pedestrian traffic by erecting temporary fence around each newly seeded area.

END OF SECTION

Attachment C: Contractor's Daily Report

WORK ORDER # _____

WORK ORDER DESCRIPTION: _____

CONTRACTOR: _____

DAY:	DATE:	CONTRACTOR'S WORK PERIOD:	FROM:	AM PM	TO:	AM PM
WEATHER:	TEMP. MAX:	MIN.		PRECIPITATION		

CONTRACTOR'S PERSONNEL			
NO.	NAME	CLASSIFICATION	HOURS WORKED
1			
2			
3			
4			
5			
6			
7			
8			
9			
10			

MAJOR EQUIPMENT ON PROJECT AND HOURS OPERATED				
NO.	DESCRIPTION	SIZE/ CAPACITY	HOURS OF OPERATION	RENT/ OWNED
1				
2				
3				
4				
5				
6				
7				

SUBCONTRACTORS	
NO.	NAME
1	SEE ATTACHED SUBCONTRACTOR'S DAILY REPORT
2	SEE ATTACHED SUBCONTRACTOR'S DAILY REPORT
3	SEE ATTACHED SUBCONTRACTOR'S DAILY REPORT
4	
5	

PARTS, SUPPLIES AND MATERIALS ON PROJECT				
NO.				
1				
2				
3				
4				
5				
6				
7				
8				

COMMENTS

AUTHOR'S

NAME: _____

TITLE: _____ SIGNATURE _____ DATE _____

Attachment D: Final Contractor's Affidavit

FINAL CONTRACTOR'S AFFIDAVIT

STATE OF _____

COUNTY OF _____

Personally appeared before me, a notary public duly authorized to administer oaths under the laws of the State of Georgia, the undersigned _____, who deposes and says that he/she is the _____ of _____, (the "Contractor") and that he/she is authorized to and does make this affidavit on behalf of said Contractor. The undersigned further deposes and says:

1. THAT pursuant to a certain contract (the "Contract") _____

dated _____, by and between Contractor and GWINNETT COUNTY (the "Owner"), Contractor agreed with Owner to construct and has completed the construction according to said Contract.

2. THAT, in connection with said Contract, all work is complete and has been performed in accordance with the terms of the Contract, that the Contractor alone has made all sub-contracts, and that the Contractor and his sub-contractors have purchased all materials and fixtures and employed all labor furnished in connection with the Contract were furnished and performed at Contractor's instance.

3. THAT all laborers, materialmen, mechanics, manufacturers, suppliers, and sub-contractors who have furnished services, labor, fixtures or materials of any one of these items have been paid and satisfied in full for all work performed, materials, fixtures or services supplied; and that said Contractor is not indebted to any person or entity for labor or materials used in connection with such construction job in any amount whatsoever.

- 4. THAT there are no outstanding claims of any nature, contractual or otherwise, or for any personal injury, death or property damage, arising from or associated with the performance of the Contractor which might be the basis of any claim, suit, lien, or demand that could be asserted against either the Owner or the Contractor.

- 5. THIS AFFIDAVIT is made pursuant to Section 44-14-361.2 of the Code of Georgia Annotated for the purpose of inducing the Owner to make final payment, and the acceptance of such final payment by Contractor shall release the Owner from any further liability under the Contract.

Made and given this _____ day of _____, 20xx.

(Contractor)

By _____

Title: _____

Sworn to and subscribed before me this _____ day of _____, 2006.

(Notary Public)

My commission expires: _____

(SEAL)

Attachment E: Job Hazard Analysis Template

JHA (Job Hazard Analysis)

Project: _____ Date: _____ Contractor: _____ Page ___ of ___
 Description of Work: _____ JSA# _____
 Prepared By: _____

Safety and Health Considerations - Check Box(s) That Apply

Falls from Elevation:	Yes <input type="checkbox"/>	No <input type="checkbox"/>	Underground Utilities:	Yes <input type="checkbox"/>	No <input type="checkbox"/>	Energized Systems/LOTO:	Yes <input type="checkbox"/>	No <input type="checkbox"/>
Confined Space(s):	Yes <input type="checkbox"/>	No <input type="checkbox"/>	Line Breaking:	Yes <input type="checkbox"/>	No <input type="checkbox"/>	Health Hazards:	Yes <input type="checkbox"/>	No <input type="checkbox"/>
Respiratory Protection:	Yes <input type="checkbox"/>	No <input type="checkbox"/>	High Voltage Work:	Yes <input type="checkbox"/>	No <input type="checkbox"/>	Scaffolding/Aerial Lifts:	Yes <input type="checkbox"/>	No <input type="checkbox"/>
Excavating/Trenching:	Yes <input type="checkbox"/>	No <input type="checkbox"/>	Work Permits:	Yes <input type="checkbox"/>	No <input type="checkbox"/>	Asbestos and/or Lead:	Yes <input type="checkbox"/>	No <input type="checkbox"/>
Public Exposure:	Yes <input type="checkbox"/>	No <input type="checkbox"/>	MEP Issues:	Yes <input type="checkbox"/>	No <input type="checkbox"/>	Hazardous Materials/Waste:	Yes <input type="checkbox"/>	No <input type="checkbox"/>
Hot Work:	Yes <input type="checkbox"/>	No <input type="checkbox"/>	Cranes/Rigging:	Yes <input type="checkbox"/>	No <input type="checkbox"/>	Working over Water:	Yes <input type="checkbox"/>	No <input type="checkbox"/>

Description of Steps to be Performed	Hazards Associated with Each Step	Required to Eliminate or Control the Hazard

JHA (Con't)

Description of Steps to be Performed	Hazards Associated with Each Step	Required to Eliminate or Control the Hazard

REVIEW SIGNATURES AND DATE

Originator

Contractor Superintendent/Engineer

Contractor Superintendent/Engineer

Date

Date

Date



Attachment F: Project Safety Acknowledgement

Subject: Project Safety Acknowledgement

Project Name: _____

Location: _____

Company/Contractor: _____

As signed and dated below, I confirm that I will be working on the above project and have received and completed Company safety training and that I have been made aware of the Facility specific safety requirements.

_____	_____	_____
Printed Name	Signature	Date
_____	_____	_____
Printed Name	Signature	Date
_____	_____	_____
Printed Name	Signature	Date
_____	_____	_____
Printed Name	Signature	Date
_____	_____	_____
Printed Name	Signature	Date
_____	_____	_____
Printed Name	Signature	Date
_____	_____	_____
Printed Name	Signature	Date
_____	_____	_____
Printed Name	Signature	Date
_____	_____	_____
Printed Name	Signature	Date
_____	_____	_____
Printed Name	Signature	Date